

**MASSACHUSETTS
BAY
TRANSPORTATION
AUTHORITY**

RAILROAD OPERATIONS DIRECTORATE

The attached Specifications are required for any construction and/or related activities on, over, under, within or adjacent to railroad property owned or controlled by the Massachusetts Bay Transportation Authority. They are intended to provide general guidelines and safeguards. Attachment "A" of Construction Guidelines and Procedures contains a summary of MBTA Railroad Operations Specifications which may be required. It is the responsibility of the Contractor to obtain all the necessary specifications for each project.

AUGUST 2014



**MASSACHUSETTS BAY
TRANSPORTATION
AUTHORITY**

RAILROAD OPERATIONS DIRECTORATE

|

GUIDELINES AND PROCEDURES

FOR CONSTRUCTION ON

MBTA RAILROAD PROPERTY

AUGUST 2014

SECTION 1. SCOPE

- 1.01 These specifications provide general safeguards to railroad property owned or controlled by the Massachusetts Bay Transportation Authority and to railroad operations upon that property during the performance of construction and/or related activities on, over, under, within or adjacent to the railroad property. They are intended as guidelines and do not represent all legal requirements which are or may be associated with construction and/or related activities. The MBTA reserves the right to require additional information and clarification and to make unilateral changes to these specifications at any time, at its sole discretion.

SECTION 2. DEFINITIONS

MBTA

Massachusetts Bay Transportation Authority; Massachusetts Realty Group, Designated Representative of MBTA Real Estate

RAILROAD COMPANY

The particular reference for the purpose of these specifications is the railroad company which maintains and/or operates or has trackage rights on the subject MBTA Railroad Property, including, but not limited to:

- Massachusetts Bay Transportation Authority (MBTA")
- Keolis Commuter Services
- Providence and Worcester Railroad (PW)
- National Railroad Passenger Corporation ("Amtrak")
- CSX Transportation ("CSX")
- Pan Am Railways (PAR) and subsidiaries The Boston and Maine Corporation (BM), The Springfield Terminal Railway Company (ST), its affiliates, successors and assigns
- Bay Colony Railroad Corporation (BLCR)

MBTA RAILROAD PROPERTY

All railroad rights of way and adjacent owned and/or controlled by the MBTA.

OWNER

The individual, utility, government, or corporation having title to the structure to be constructed upon, over or adjacent to the railroad property owned or controlled by the MBTA.

UTILITY

Public or private communication, water, sewer, electric, gas and petroleum companies or other entity governed by the Massachusetts Department of Public Utilities.

GOVERNMENT

Federal, State, Town, City, County and other forms of government.

CORPORATION

Any firm duly incorporated under laws of a state government.

INDIVIDUAL

Any party not defined by "Owner, Utility, Government or Corporation".

CONTRACTOR

The individual, partnership, firm, corporation or any combination thereof, or joint venture, contracting with a Utility, Government, Firm, Company, Corporation or Individual for work to be done on, over, under, within or adjacent to MBTA Railroad Property.

OWNER OR ITS CONTRACTOR

As used in these specifications, does not affect the responsibilities of either party for work conducted on, over, under, within or adjacent to MBTA Railroad Property.

CONSTRUCTION DRAWINGS

Original drawings, submitted to the Engineer by the Contractor pursuant to the Work, including, but not limited to: stress sheets, working drawings, diagrams, illustrations, schedules, performance charts, brochures, erection plans, falsework plans, framework plans, cofferdam plans, bending diagrams for reinforcing steel, or other supplementary plans or similar data which are prepared by the Contractor or a Subcontractor, manufacturer, supplier or distributor, and which the Contractor is required to submit for review and approval by the MBTA. Working Drawings: Contractor prepared plans for temporary

structures and facilities. Working Drawings for elements of work which may affect safety of persons or property included but are not limited to Contractor's plans for temporary structures such as decking, temporary bulkheads, support of utilities, and for such other work as may be required for construction but which do not become an integral part of completed project.

SECTION 3. SUBMITTALS

3.01 INITIAL CONTACT

- A. The MBTA owns the majority of the railroad lines in eastern Massachusetts. Many of these railroad lines are operated for passenger service, using a Railroad Company as an operating and maintaining Contractor. Some of the railroad lines are used for freight-only service, operated and maintained by other Railroad Company(s). In most instances, both passenger and freight service are operated over the same railroad lines.
- B. All of the MBTA railroad lines are maintained by a designated Railroad Company(s), excepting rapid transit and light rail lines. The maintaining Railroad Company(s) has rights and responsibilities, in addition to the MBTA's property owner's rights.
- C. To obtain further information concerning License Agreements, Easements, Licenses for Entry and performance of construction related activities which affect MBTA Railroad Property, a written request may be forwarded to:

License Administrator
Massachusetts Realty Group
20 Park Plaza, Suite 1120
Boston, MA 02116

or you may access the website at www.mbtarealty.com

The License Administrator is also the contact person for information concerning rapid transit and light rail lines.

SECTION 4. PLANS AND SPECIFICATIONS

- 4.01 SCOPE: It is the intent of the MBTA to eliminate or minimize any risk involved with construction or related activities on, over, under, within or adjacent to MBTA Railroad Property. Therefore, MBTA approval and

frequently one or more Railroad Company(s) approval of construction plans and specifications for all phases of a proposed project affecting MBTA Railroad Property is required.

- 4.02 GENERAL: If requested by the License Administrator, the applicant must provide six (6) sets of plans and specifications to the License Administrator. These plans and specifications must meet the approval of the Railroad Company(s) and the MBTA prior to the start of construction. These plans are to be prepared in sizes as small as possible (no smaller than 11" x 17") and are to be folded to an 8-1/2 inch by 11 inch size (folded dimensions) with a 1-1/2 inch margin on the left side and a 1 inch margin on the top.
- A. After folding, the title block and other identification of the plans shall be visible at the lower right corner, without the necessity of unfolding. Each plan shall bear an individually identifying number and an original date, together with subsequent revision dates, clearly identified on the plan.
 - B. All plans are to be individually folded or rolled and where more than one plan is involved, they shall be assembled into complete sets before submission to the MBTA.
- 4.03 PLANS: The plans are to show all the work which may affect MBTA Railroad Property, and contain a location map and plan view of the project, with appropriate cross sections and sufficient details. The proposed construction or related activities must be (orated with respect to top of rail (vertical) and center line of track (horizontal)). The plan must also include railroad stationing, property lines and subsurface soil conditions. The subsurface information is to be in the form of boring logs with the borings located on the plan view. The plans must be stamped by a Professional Engineer registered in the state of Massachusetts. (The purchase of railroad valuation plans may be arranged by contacting MBTA Engineering offices at (617) 222-6178).
- 4.04 SPECIFICATIONS: The specifications summarized on Attachment "A" attached hereto are the Standard Specifications of the MBTA Railroad Operations Department and apply to all types of construction work affecting MBTA Railroad Property.
- A. In addition to "Maintenance and Protection of Railroad Traffic" and "Insurance Specifications" which are required for all work on, over, under, within or adjacent to MBTA Railroad Property, certain other Specifications contained in Attachment "A" shall be incorporated into construction/engineering submittals when deemed necessary by the MBTA and/or Railroad Company(s). (The purchase

of additional specifications may be arranged by contacting MBTA offices at (617) 222-3448 or visiting Massachusetts Realty Group website at www.mbtarealty.com.

SECTION 5. SUBMISSION REVIEW

- 5.01 An initial submission of six (6) sets of plans and specifications for MBTA review must be forwarded to the License Administrator, along with a completed MBTA Application for Entry (Attachment "B"). The submission will be circulated for review and comment to MBTA departments which may be impacted by the proposed project. If approved by the MBTA, the Railroad Company(s) will review.
- 5.02 The applicant is advised that the MBTA's initial review process requires a minimum forty-five (45) day period, prior to the Railroad Company(s) involvement, and additional processing time may be required for specific documents (See Section 9).

SECTION 6. INSPECTIONS/PAYMENTS

- 6.01 The MBTA may inspect all projects affecting MBTA Railroad Property at least twice, at the applicant's sole expense. The actual number of MBTA inspections will depend on the size and complexity of the project.
- 6.02 The MBTA may utilize Railroad Company inspectors and flagmen for daily inspection and protection of rail traffic during the term of the construction period or related activities. The Owner or Contractor will be responsible for advance payment of all associated fees.
- 6.03 Advance payments to the MBTA for construction/engineering review of plans and specifications by MBTA staff must be submitted when initial contact is made with the License Administrator. Payments shall be in the form of check or money order, made payable to the Massachusetts Bay Transportation Authority.
- 6.04 Advance payments covering the services for Railroad Company(s) construction/engineering review of plans and specifications, or services of an inspector or flagman, will be paid directly to the Railroad Company(s). The MBTA will advise when such services are required, and the Railroad Company(s) will advise of the amount of the required advance payment.

SECTION 7. EXAMINATION OF PLANS OR PROPERTY

- 7.01 The Contractor/Applicant shall have no claim for any differences between MBTA valuation plans and the actual conditions encountered in the field.

SECTION 8. INSURANCE AND INDEMNIFICATION

- 8.01 Prior to entry upon MBTA Railroad Property, insurance will be provided to and approved by the MBTA and affected Railroad Company(s), as outlined in "Insurance Specifications."
- 8.02 Additionally, all MBTA Licenses and Letters of Authorization contain a clause for Indemnifying MBTA and the Railroad Company(s) from and against any and all liabilities, losses, damages, costs, expenses, causes of action, suits, claims, demands and/or judgments of any nature whatsoever that may be imposed upon or incurred by or asserted against the MBTA or the Railroad Company(s).

SECTION 9. LEGAL DOCUMENTS FOR TEMPORARY AND PERMANENT INSTALLATIONS

- 9.01 The nature of entry upon or installation within MBTA Railroad Property will determine the authorizing document to be issued. Listed below are brief descriptions of MBTA documents:
- A. **License for Entry:** Authorizes short-term entry for purposes of survey, inspection, test borings, access, etc. One time administrative/engineering/legal review and access fees.
 - B. **License Agreement:** Authorizes installations, subject to termination clause, if Applicant chooses not to pursue an Easement. One time administrative/engineering/legal review fee as well as annual rental fee.
 - C. **Easement:** Authorizes permanent installations in form suitable for recording at Registry Deeds. All easements are non-exclusive and subject to relocation at the Owner's expense, for Mass transportation purposes:
 - 1. Easements must receive MBTA Board of Directors approval, which involves considerable time. Once approved by the Board of Directors and upon payment in full to the MBTA, a License for Construction is issued. Upon final inspection and acceptance of the installation by the MBTA the Easement document is issued.
 - 2. Permanent Subsurface Easement widths are limited to a maximum three-foot distance on either side of the occupation.

3. a) A one-time administrative/engineering/legal review fee, in addition to value of easement, as established by independent appraisal conducted at the Applicant's expense.
- b) If easement size is minimal, as determined by the MBTA, a fixed fee, encompassing administrative/engineering/legal review fee.

D. **Letter of Authorization**: Authorizes installations and construction activities in association with Master License Agreements. One-time administrative/engineering/legal review as well as access and/or annual fees.

ATTACHMENT "A"

SUMMARY OF MBTA RAILROAD OPERATIONS SPECIFICATIONS

I. GUIDELINES AND PROCEDURES FOR CONSTRUCTION ON MBTA RAILROAD PROPERTY

This general specification outlines the immediate design requirements and methodology for progressing construction activities on MBTA Railroad Property.

II. MAINTENANCE AND PROTECTION OF RAILROAD TRAFFIC

This specification will be included in ALL work requirements on MBTA Railroad Property, and covers rules, requirements, and protective services or any construction-related activity on MBTA Railroad Property. Supplemental specifications are listed below.

III. INSURANCE SPECIFICATIONS

This specification details the required insurance coverages and limits of the MBTA and Railroad Company(s).

IV. PIPELINE OCCUPANCY SPECIFICATIONS

This specification details requirements for all pipeline borings/jacking's and open cuts on or adjacent to MBTA Railroad Property, as well as requirements for Drawing submittals.

V. SPECIFICATIONS FOR WIRE CONDUIT AND CABLE OCCUPATIONS

This specification details requirements for clearances and installations of parallel and overhead crossings on MBTA Railroad Property, as well as requirements for Drawing submittals.

VI. BRIDGE ERECTION DEMOLITION AND HOISTING OPERATIONS

This specification details plan preparation for demolition and/or hoisting and erection of structures on and over MBTA Railroad Property.

VII. TEMPORARY SHEETING AND SHORING

This specification details requirements for plan preparation and calculations necessary for sheeting and shoring for construction on or adjacent to MBTA Railroad Property.

VIII. BLASTING SPECIFICATIONS

This specification outlines submittals, details and requirements for blasting on or adjacent to MBTA Railroad Property.

IX. TEMPORARY PROTECTION SHIELDS FOR DEMOLITION AND CONSTRUCTION

This specification outlines criteria for plan preparation related to protection of MBTA Railroad Property when work takes place on overhead structures.

X. INDUSTRIAL SIDE TRACK SPECIFICATIONS

This specification outlines minimal requirements for materials and installation submission for private railroad side tracks up to MBTA property line and/or clearance point. Other provisions, site-specific, may be required, including signal protection maintenance and protection of railroad traffic.

XI. RIGHT OF WAY FENCING SPECIFICATIONS

This specification details the requirements for the materials, construction and installation of standard right of way fence.

XII. TEST BORING SPECIFICATIONS

This specification outlines procedures and requirements for the performance of test borings on MBTA Railroad Property.

XIII. FIBER OPTIC CABLE SPECIFICATIONS

This specification details requirements for design and installation of fiber optic cables on MBTA Railroad Property; and is modified by site-specific requirements, including the construction methodology, location and type of fiber optic cables and protection conduits.

XIV. RAILROAD OPERATIONS BOOK OF STANDARD PLANS, TRACK AND ROADWAY, MW-I SPECIFICATIONS FOR CONSTRUCTION AND MAINTENANCE OF TRACK

Certain construction activities may require obtaining this comprehensive package if rail construction details and requirements are related to the track operation.

XV. COMMUTER RAIL DESIGN STANDARDS

ATTACHMENT "B"

**MASSACHUSETTS BAY TRANSPORTATION AUTHORITY
APPLICATION FOR ENTRY UPON MBTA RAILROAD, TRANSIT,
OR OTHER PROPERTY**

Date _____

1. Name of Applicant: _____
2. Type of Entity (Partnership, Corporation, Proprietorship, Public Authority, etc.):

3. Mailing Address: _____
4. Contact info: _____
5. If incorporated, state of incorporation: _____
6. Proposed license term commencement date: _____
7. Agents for applicant for service of notice or process: _____

8. Administrative Fee: 1,000.00 paid with application
9. If plan reviews by The MBTA Design and Construction are deemed necessary the following fee shall apply:

Design and Construction Plan Review Fee: 1,600.00 Paid with Application Fee
10. Applicant shall submit Drawings in pdf form and one set of paper Drawings to License Administrator
11. If applicant is self-insured, please provide limits of self-insurance and attach copies of authorizing legislation or certification thereof: _____

12. If applicant is authorized by public authority to enter into such license agreement, please provide:

Motion, Resolution, or Ordinance No.: _____

Date of Adoption: _____

Adopted by: _____

13. Is the applicant seeking permission to perform environmental testing and/or assessment on Authority property?

a) Is the proposed testing and/or assessment required by the Massachusetts Contingency Plan ("MCP")?

b) What is the Release Tracking number and current status of the MCP work?

14. Name, title and email of applicant's officer authorized to sign agreement: _____

Project Description

1. Brief description of construction (including types of pipes and other attachments or ancillary facilities to be installed on MBTA Railroad Property): _____

2. Brief description of purpose of entry and/or installation: _____

Space Requirements
[*To Be Provided*]

Technical Information

1. Is this occupancy within the limits of a public road? _____
Attach copies of applicant's franchise to occupy such space.
2. If occupancy is under, over, through, or attached to undergrade or overhead bridge, who owns such bridge? _____

3. Type of occupancy (facility):

- a) Exact Length of MBTA Railroad Property to be burdened by occupancy: _____

- b) Width of excavation facility on MBTA Railroad Property:

- c) Number of manholes: _____

A. Aerial or underground wire and cable:

(1) Telephone and other communication cables:

Number of cables: _____

Number of pairs/cable: _____

Are these composite coaxial cables? _____

(2) Power Cables:

Number of cables/size: _____

Number of volts per conductor: _____

Are these pipe-type cables consisting of one or more high voltage cables encased in steel pipe under inert oil pressure? _____

(3) Fiber optic cables:

Number of cables: _____

Number of distribution cables: _____

Number of transmission cables: _____

Number of strands in each cable: _____

Number of repeater stations on MBTA Railroad Property: _____

Systems (check one):

Transmission _____

Distribution _____

Sensor _____

(4) Number of spare or unoccupied ducts to be installed: _____

B. Pipes and Sewers

(1) Circular line carrying no pressure:

Number of pipes: _____

Number of inches of inside nominal diameter per pipe: _____

(2) Circular lines under pressure and carrying non-flammable, non-explosive, or non-combustible supporting materials, except coal and slurry:

Number of pipes: _____

Number of inches of inside nominal diameter per pipe: _____

(3) Circular lines under pressure and carrying flammable, explosive, or combustible supporting material:

Number of pipes: _____

Number of inches of inside nominal diameter per pipe: _____

(4) Non-circular pipe: _____

(5) Will a pipe tunnel be constructed? _____

(6) Will pipe be supported by MBTA structures, bridges, etc.? _____

Explain: _____

(7) Will pipe be attached to MBTA structures, bridges, etc.? _____

Explain: _____

C. Ancillary Facilities

Number of wooden poles to be installed on MBTA Railroad Property:

Other wooden supporting structures: _____

Steel supporting structures: _____

Explain: _____

Number of braces, stub poles: _____

Number of guy wires anchored on MBTA Railroad Property: _____

Number of span guy wires crossing MBTA Railroad Property: _____

D. Attachments

- (1) Attachment of aerial wires and cables to poles or other structures of MBTA used in wire line construction or support:

Number of wires attached to MBTA cross-arm: _____

Voltage of wire: _____

Number of wires attached to applicant's cross-arm or bracket: _____

Voltage of wire: _____

Number of cross-arms or brackets attached to MBTA poles: _____

- (2) Attachment of aerial wires and cables to building or structures other than those used in wire line construction or support:

Number of wires or cables attached to MBTA's building or structures:

- (3) Attachment of cable terminals to poles, buildings, or structures including highway bridges, railroad bridges over highways, or other bridges of MBTA:

Number of cable terminals, loading coils, transformers, or like devices attached:

Explain: _____

E. Guy wire crossings and overhanging cross-arms and power wires of pole lines outside MBTA right-of-way.

Number of guy wires crossing MBTA Railroad property but not anchored thereon: _____

Number of cross-arms overhanging MBTA Railroad Property from poles located outside thereof: _____

Number of cross-arms on any poles: _____

It is hereby understood and agreed that the undersigned applicant will bear any and all costs associated with MBTA's preliminary and final engineering review in connection with this application. Any charges in excess of the initial advance payment will be billed directly to the address indicated in Item #3 above.

Agent: _____

For: _____
Name of Applicant

By: _____
(Title)

(Date)

REVENUE ENFORCEMENT AND PROTECTION PROGRAM CERTIFICATION

Pursuant to M.G.L. Ch. 62C, Sec. 49A, I certify under penalties of perjury that I (my company), to my best knowledge and belief, have (has) filed all state tax returns and paid all state taxes required under law.

Social Security Number or
Federal Identification Number

Signature of Individual or Corporate Name

By: _____
Corporate Officer
(If applicable)

Date: _____

EMPLOYER'S CERTIFICATE OF COMPLIANCE WITH
MASSACHUSETTS EMPLOYMENT SECURITY LAW

Pursuant to G. L. C. 151A, Sec. 19A (b), I _____

on behalf of (Name of Employer) _____,

D.E.T. ID Number _____, certify under the penalties of perjury¹ that the
aforementioned employer has complied with all laws of the Commonwealth relating to contributions
and payments in lieu of contributions.

Signed under the penalties of perjury this _____ day of _____, 20__.

Name of Employer

Signature

Name (Printed)

Title (Printed)

¹ The employer may certify its compliance if it has entered into and is complying with a repayment agreement satisfactory to the Commissioner or there is a pending adjudicatory proceeding or court action contesting the amount due pursuant to G. L. C. 161A, Sec. 19A(c).

STATEMENT REGARDING BENEFICIAL INTEREST

In compliance with the provisions of Chapter 7, Sec. 40J of the General Laws, I hereby state, under the penalties of perjury, that the true names and addresses of all persons who have or will have a direct or indirect beneficial interest in the real property subject to this Application dated

_____, 20___,

between _____ as applicant/tenant, for premises in the building (on the site) know as _____, and located at _____

_____ are listed below.

Name and residence of all persons with beneficial interests:

1. _____
2. _____
3. _____
4. _____
5. _____
6. _____

Signed: _____

Title: _____

Date: _____

ATTACHMENT "C"

REFERENCED STANDARDS AND SPECIFICATIONS

- A. Wherever standards or specifications issued by a recognized industry association or regulatory body are referenced in these Specifications, the reference shall be interpreted as incorporating the referenced standard or specification in total into these Specifications as applicable. In the event of a difference between referenced standard or specifications and these Specifications, the latter shall govern.
- B. Technical Reference Abbreviations - References are made to recognized standards by use of the acronyms listed below. Addresses are included for convenience, and the accuracy of the addresses is not warranted:

AA	The Aluminum Association 900 19th Street NW Washington, DC 20006
AAR	The Association of American Railroads American Railroads Building 50 F Street NW Washington, DC 20001
AASHTO	American Association of State Highway and Transportation Officials 444 North Capitol Street NW Suite 249 Washington, DC 20001
ACGIH	American Conference of Governmental Industrial Hygienists 1330 Kemper Meadow Drive Cincinnati, OH 45240
ACI	American Concrete Institute P. O. Box 19150 Detroit, MI 48219
AFPA	American Forest and Paper Association 1111 19th Street, NW Suite 700 Washington, DC 20036

AIA	American Insurance Association 1130 Connecticut Avenue NW Washington, DC 20036
AISC	American Institute of Steel Construction Inc. 1 East Wacker Drive Suite 1300 Chicago, IL 60601
AISI	American Iron and Steel Institute 1101 17th Street NW Suite 1300 Washington, DC 20036-4700
AITC	American Institute of Timber Construction 7012 South Revere Parkway Suite 140 Englewood, CO 80112
ANSI	American National Standards Institute 11 West 42nd Street New York, NY 10036
APA	American Plywood Association P. O. Box 11700 Tacoma, WA 98411
APHA	American Public Health Association 1015 15th Street NW Washington, DC 20005
AREA	American Railway Engineering Association 50 F Street NW Washington, DC 20001
ASCE	American Society of Civil Engineers 345 East 47th Street New York, NY 10017
ASHRAE	American Society of Heating, Refrigerating and Air Conditioning Engineers 1791 Tullie Circle, NE Atlanta, GA 30329
ASME	American Society of Mechanical Engineers 345 East 47th Street New York, NY 10017

ASTM	American Society for Testing and Materials 1916 Race Street Philadelphia, PA 19103
AWPA	American Wood Preservers' Association P. O. Box 286 Woodstock, MD 21163-0286
AWS	American Welding Society 550 NW 42nd Avenue Miami, FL 33126
AWWA	American Water Works Association, Inc. 6666 W. Quincy Avenue Denver, CO 802350
CSI	Construction Specifications Institute 601 Madison Avenue Alexandria, VA 22314-1791
FHA	Federal Highway Administration 400 7th Street SW Washington, DC 20590
FRA	Federal Railroad Administration 403 7th Street SW Washington, DC 20590
ICBO	International Conference of Building Officials 5360 Workman Mill Road Whittier, CA 90601
IIA	Incinerator Institute of America 60 East 42nd Street New York, NY 10017

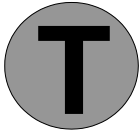

**MASSACHUSETTS BAY
TRANSPORTATION
AUTHORITY**

RAILROAD OPERATIONS DIRECTORATE

||

MAINTENANCE AND PROTECTION OF RAILROAD TRAFFIC

AUGUST 2014

SECTION 1. GENERAL

- 1.01 The Contractor should note that these specifications govern proposed work that involves construction on, over, under, within or adjacent to MBTA Railroad Property. Requirements must be strictly observed whenever the tracks, structures, or properties of the MBTA are involved or affected.
- 1.02 If the tracks or other facilities of the MBTA are endangered, the Contractor shall immediately perform such work as directed by the Railroad Company(s), and upon failure of the Contractor to carry out such orders immediately, the Railroad Company(s) may take whatever steps are necessary to restore safe conditions. The cost and expense to the Railroad Company(s) and/or MBTA of restoring safe conditions or of any damage to the MBTA's trains, tracks, or other facilities caused by the Contractors' or subcontractors' operations, shall be at the sole expense of the Contractor and will be collected as appropriate. This cost shall be paid for by the Contractor and may be deducted from any monies due and that may become due to the Contractor.
- 1.03 Before entering upon MBTA Railroad Property:
- A. The Owner or its Contractor shall be fully informed of all requirements of the MBTA pertaining to the specific project and shall conduct all their work accordingly. Any questions relating to the requirements of the MBTA should be directed to the Director of Engineering for MBTA Railroad Operations or their authorized representative.
 - B. The Owner or its Contractor shall execute an MBTA License for Entry, and shall provide the MBTA and Railroad Company(s) with the information required in the "Insurance Specifications".
 - C. The Owner or its Contractor shall take note that if an excavation is to be made within a 2 to 1 slope line commencing 5.5 feet from the centerline of track, they shall be required to submit the proposed method of soil stabilization for approval by the Director of Engineering for MBTA Railroad Operations.
 - D. The Owner or its Contractor shall furnish detailed plans for falsework, bracing, sheeting, or other supports adjacent to the tracks for approval by the Director of Engineering for MBTA Railroad Operations and the Railroad Company(s), and the work shall be performed in accordance with temporary "Sheeting and Shoring". All plans and calculations shall be stamped by a Registered Professional Engineer.
 - E. The Owner or its Contractor shall give written notice to the Director of Engineering for MBTA Railroad Operations and the applicable

Railroad Company(s) at least 21 days in advance of starting work or locating equipment at the site.

- F. The Owner or its Contractor shall make all necessary arrangements with the MBTA before entering upon MBTA Railroad Property.

1.04 After entering upon MBTA Railroad Property:

- A. The Owner or its Contractor shall have, in their possession on the job site, the contract plans and specifications which bear the stamp of approval of the Director of Engineering for MBTA Railroad Operations or Railroad Company(s). The Owner or its Contractor shall conduct all their work according to these plans and specifications.
- B. All work shall be performed and completed in a manner fully satisfactory to the MBTA Chief Engineering Officer or authorized representative(s). Railroad Company(s) inspection of the work shall be conducted at any time and the Owner or its Contractor shall cooperate fully with the MBTA and Railroad Company(s) representatives.
- C. All equipment used by the Owner or its Contractor on MBTA Railroad Property may be inspected by the Railroad Company(s) and shall not be used if considered unsatisfactory by the Railroad Company(s) representative. Equipment of the Owner or its Contractor to be used adjacent to tracks shall be in first class condition so as to positively prevent any failure that would cause delay in the operation of trains or damage to MBTA or railroad facilities. Equipment shall not be placed or put into operation adjacent to a track without first obtaining the permission of the Railroad Company(s).
- D. Operators of such equipment must be properly licensed and may be examined by the Railroad Company(s) representative to determine their fitness. If it is determined that they are unfit to work, then the Owner or its Contractor shall remove them from MBTA Railroad Property.
- E. If the Director of Engineering for MBTA Railroad Operations deems it necessary, the Owner or its Contractor shall furnish and erect in close proximity to the site of the work a suitable, furnished shelter with lights, heat, telephone, etc., for use by Railroad Company(s) personnel providing services to the Owner's or Contractor's work.
- F. The Owner or its Contractor's work shall be performed in such manner that the tracks, train operations and appurtenances of the MBTA and the Railroad Company(s) will be safeguarded.

- G. Open excavations shall be suitably planked and safeguarded when construction operations are not in progress.
- H. Blasting will be permitted under or adjacent to tracks only after proof that blasting is required and all methods have been approved by the Director of Engineering for MBTA Railroad Operations and the Railroad Company(s). All blasting operations must comply with the MBTA's "Blasting Specifications".
- I. The Owner or its Contractor shall be fully responsible for all damages arising from their failure to comply with the requirements of these specifications. Failure to comply may result in their removal from MBTA Railroad Property, at the MBTA's sole discretion.

SECTION 2. RULES, REGULATIONS, AND REQUIRMENTS.

- 2.01 Railroad traffic shall be maintained at all times with safety and continuity, and the Contractor shall conduct all operations on, over, under, within or adjacent to MBTA Railroad Property within the rules, regulations, and requirements of the Railroad Company(s) and/or MBTA. The Contractor shall be responsible for acquainting themselves with such requirements as the Railroad Company(s) and/or MBTA may demand.
- 2.02 The Contractor shall obtain verification of the time and schedule of track occupancy from the Railroad Company(s) before proceeding with any construction or demolition work on, over, under, within or adjacent to MBTA Railroad Property. The work shall not proceed until the plans and method of procedure have been approved by the Director of Engineering for MBTA Railroad Operations or their authorized representative.
- 2.03 All work to be done on, over, under, within or adjacent to MBTA Railroad Property shall be performed by the Contractor in a manner satisfactory to the MBTA and the Railroad Company(s), and shall be performed at such times and in such manner, as to not interfere with the movement of trains or operations upon the tracks of the MBTA. The Contractor shall use all necessary care and precaution in order to avoid accidents, delays or interference with the MBTA's trains or other property.
- 2.04 The Contractor shall give written notice to the Railroad Company(s) at least twenty- one (21) days prior to the commencement of any work, or any portion of the work, by the Contractor or their subcontractors on, over, under, within or adjacent to MBTA Railroad Property, in order that necessary arrangements may be made by the Railroad Company(s) to protect railroad operations.

- 2.05 If deemed necessary by the Railroad Company(s), it may assign an inspector and/or engineer who will be placed on the work site during the time the Contractor or any subcontractor is performing work on, over, under, within or adjacent to MBTA Railroad Property. The cost and expense will be paid directly by the contracting party with an advance deposit to the Railroad Company(s), unless otherwise approved.
- 2.06 Before proceeding with any construction or demolition work, on, over, under, within or adjacent to the MBTA's Railroad Property, a pre-construction meeting shall be held at which time the Contractor shall submit for approval of the MBTA and Railroad Company(s), Drawings, computations, and a detailed description of the method for accomplishing the construction work, including methods of protecting railroad operations. Such approval shall not serve in any way to relieve the Contractor of complete responsibility for the adequacy and safety of the referenced methods.
- 2.07 During any demolition procedure, the Contractor must provide an approved shield to prohibit all debris from falling onto MBTA Railroad Property. A protective fence must be erected at both ends of the project to prohibit trespassers from entering MBTA Railroad Property.
- 2.08 Cranes, shovels, or any other equipment shall be considered to be fouling the track when located in such position that failure of same with or without load brings the equipment within the fouling limit. The Contractor's employees and equipment will not be permitted to work near overhead wires or apparatus.
- 2.09 The Contractor shall conduct their work and handle their equipment and materials so that no part of any equipment should foul an operated track or wire line without the written permission of the Railroad Company(s). When it becomes necessary for the Contractor to foul any track, they must give the Railroad Company(s) written notice of their intentions twenty-one (21) days in advance, so that if approved, arrangements may be made for proper protection of the Railroad Company(s).
- 2.10 The Contractor's equipment shall not be placed or put into operation adjacent to tracks without first obtaining permission from the Railroad Company(s). Under no circumstances shall any equipment or materials be placed or stored within fifteen (15) feet from the centerline of the closest track.
- 2.11 Materials and equipment belonging to the Contractor shall not be stored on MBTA Railroad Property without first having obtained permission from the Railroad Company(s), and such permission will be on the condition that the MBTA and/or Railroad Company(s) will not be liable for damage to such materials and equipment from any cause. The Contractor shall keep the

tracks adjacent to the site clear of all refuse and debris that may accumulate from construction operations, and shall leave the MBTA Railroad Property in the condition existing before construction commencement. Equipment repair, refueling or extended storage is prohibited on MBTA Railroad Property.

- 2.12 The Contractor shall consult the Railroad Company(s) in order to determine the type of protection required to insure safety and continuity of railroad operations. The railroad field engineer may assign track foremen, flagmen, signalmen or other employees deemed necessary for protective services by the Railroad Company(s), to insure the safety of trains and MBTA Railroad Property. The cost of same shall be paid directly by the contracting party with an advance deposit to the Railroad Company(s), unless otherwise approved.
- 2.13 The provision of such protective services, and other precautionary measures, shall not relieve the Contractor from liability for the cost of any and all damages caused by their operations.
- 2.14 The Railroad Company(s) will require protection during all periods when the Contractor is working on, over, under, within or adjacent to MBTA Railroad Property or as may be deemed necessary. When protection is required, the Contractor shall make the request in writing to the Railroad Company(s) at least twenty-one (21) days before such protection is required.
- 2.15 The Contractor shall not bill the Railroad Company(s) or MBTA for any work which they are proposing to perform, unless the Railroad Company(s) or MBTA authorizes the said work in writing. This work must be to the benefit of the MBTA or Railroad Company(s).
- 2.16 The Contractor, subcontractor and respective employees who will come within the limits of the MBTA Railroad Property, must first attend the Railroad Company(s) Safety Orientation Class. They are required to comply with the Railroad Company(s) Safety Requirements throughout the entire construction period. All costs associated with compliance of the Railroad Company(s) Safety Requirements will be at the sole expense of the Contractor and subcontractors.
 - A. The Contractor for the project must appoint a qualified person who will be designated as a Safety Representative. They must be approved by the Railroad Company(s) Safety Representative. The Contractor's designee will be responsible to give Safety Orientation to the Contractor's/subcontractor's employees who will come onto the MBTA's Railroad Property for short periods of time after the initial Safety Orientation Class has been given by the Railroad Company(s). The Contractor's designee will keep the Railroad Company(s) Safety Representative informed of the temporary employees who received Safety Orientation. The Railroad Company(s)

Safety Orientation Class will be repeated when employee turnover or groups of Contractor's and subcontractor's employees are such that another Railroad Company(s) Safety Orientation Class is justified.

- B. All Contractors shall follow established safety procedures and remain 15 feet or more from the closest rail of the closest track. When it becomes necessary for Contractors to encroach on this 15 foot limitation, the proper fouling procedures will be arranged with the Railroad Company(s).
 - C. Contractors will establish the 15 foot foul line by installing stakes and taping off the area prior to beginning work.
- 2.17 Upon completion of the work, the Contractor shall remove from the MBTA Railroad Property, all machinery, equipment, surplus materials, falsework, rubbish, temporary buildings and other property of the Contractor, or any subcontractor, and shall leave MBTA Railroad Property in a condition satisfactory to the MBTA and Railroad Company(s). Failure to comply will result in Railroad Company(s) forces restoring MBTA Railroad Property at the Contractor's expense.
- 2.18 The Contractor will pay the Railroad Company(s) directly, for all protective services unless otherwise approved. The services are performed to insure safe operation of trains when construction work would, in the Railroad Company(s) opinion, be a hazard.

SECTION 3. DEFINITION OF HAZARD

- 3.01 Protection Services will be required whenever the Contractor is performing work on, over, under, within or adjacent to MBTA Railroad Property. This will include excavating, sheeting, shoring, erection, removal of forms, handling material, using equipment which by swinging or by failure could foul the track, and when any other type of work being performed, in the opinion of the Railroad Company(s), requires such service.
- 3.02 Railroad operations will be considered subject to hazard when explosives are used in the vicinity of MBTA Railroad Property during the driving or pulling of sheeting for footings adjacent to a track, when erecting structural steel across or adjacent to a track, when operations involve swinging booms or chutes that could in any way come closer than 5 feet to the center line of a track or wire line. None of these or similar operations, shall be carried on without Railroad Company(s) protective services personnel on site.
- 3.03 A signal line or communication line shall be considered fouled and subject to hazard when any object is brought closer than ten (10) feet to any wire or cable. An electrical supply line shall be considered fouled and subject to hazard when any object is brought closer than ten (10) feet to any

wire of the line.

- 3.04 As excavation approaches pipes, conduits, or other underground structures on or adjacent to MBTA Railroad Property, digging by machinery shall be discontinued and the excavation shall continue by means of hand tools. All existing pipes, poles, wires, fences, property line markers, and other structures, which the MBTA and/or Railroad Company(s) decides must be preserved in place, shall be carefully protected from damage by the Contractor or its Owner. Should such items be damaged, they shall be restored by the Railroad Company(s), at the Owner's or Contractor's sole expense to the original condition prior to construction commencement. If any excavation is taken beyond the work limit indicated on the approved Drawings or prescribed herein, the Owner or its Contractor shall backfill and compact to the satisfaction of the Railroad Company(s) at the Contractors expense.

SECTION 4. BACKFILL

4.01 Backfilling

- A. All backfill material adjacent to any Railroad Company(s) facility shall be approved by the Railroad Company(s). Backfill material shall be free from hard lumps and clods larger than 3 inches in diameter, and free from large rocks or stumps. Uniformly fine material shall be placed next to any pipe liable to dent or break.
- B. All backfill material shall be compacted at or near optimum moisture content, in layers not exceeding 6 inches in compacted thickness by pneumatic tampers, vibrator compactors, or other approved means to the base of the railroad subgrade. Material shall be compacted to not less than 95 percent of AASHTO T 99, Method C. The Contractor will be required to supply to the job site, ballast stone (AREA #4) to be installed by the Railroad Company(s).

4.02 Certification

The Owner or its Contractor shall provide testing, through the use of a testing lab or Professional Engineer, to insure that the in place density of the backfill meets or exceeds the requirements of Section 4.01(B). Written certification of the tests shall be given to the Railroad Company(s) immediately upon completion of the test.

4.03 Alternate

In the case of an open cut crossing of the MBTA Railroad Property, the Owner or its Contractor may backfill with concrete having a three-day compressive strength of 1000 psi to the base of the track subgrade. This

may be used in lieu of providing the certification of proper compaction when using gravel backfill. The Owner or its Contractor will be required to supply to the job site, ballast stone (AREA #4) to be installed by the Railroad Company(s).

SECTION 5. CLEARANCES

- 5.01 Staging falsework or forms shall at all times be maintained with a minimum vertical clearance of 226" above top of the high rail and a minimum horizontal clearance of 15' from the center line of track.

SECTION 6. PROTECTION SERVICES

- 6.01 The MBTA shall require railroad inspection and may require railroad flagging. Prior to the start of any work on MBTA Railroad Property, the Owner or its Contractor shall submit a deposit to the amount required by the Railroad Company(s). If Railroad Company(s) expenses are greater than the amount of deposit, the Owner or its Contractor shall reimburse the Railroad Company(s) for the balance when billed, and, if the Railroad Company(s) expenses are less than the amount of deposit, the Railroad Company(s) will refund the balance to the Owner or its Contractor. The Railroad Company(s) reserves the right to request additional deposits as project work progresses.
- 6.02 If the MBTA or Railroad Company(s) determines that flagmen are necessary, the number required shall be on duty at the site during the hours of hazard described under Section 3. No work shall be performed if flagmen are required but are not on duty.
- 6.03 It shall be the responsibility of the Owner or its Contractor to keep the MBTA and Railroad Company(s) informed at all times when the Owner or its Contractor shall be working on, over, under, within or adjacent to MBTA Railroad Property and creating the hazards described under Section 3. Failure of the Owner or its Contractor to give the MBTA and Railroad Company(s) suitable advance notice of hazardous operation shall result in the shutdown of the work by the Railroad Company(s), until such time as sufficient numbers of flagmen are on duty at the site. If this becomes a repeat occurrence, the Contractor will be removed from the project.
- 6.04 The Railroad Company(s) will make its best effort to provide protective services personnel. Should the situation arise where such personnel are not available, Contractor operations must cease. The Railroad Company(s) is not liable for any monetary claims incurred during the absence of protective services personnel.

SECTION 7. INSPECTION

7.01 If deemed necessary by the Director of Engineering for MBTA Railroad Operations, the MBTA will furnish and assign an engineer(s) for inspection and the Railroad Company(s) will furnish an appropriate inspector for general inspection purposes or for general protection of MBTA Railroad Property and operations during construction. All protection services will be at the expense of the Owner or its Contractor.

SECTION 8. EXTRA-CONTRACT SERVICES

8.01 Temporary and permanent changes of tracks and all railroad utilities made necessary by the work of the Contractor, will be made by the MBTA or Railroad Company(s) at the expense of the Owner or its Contractor.

8.02 All other changes made or services furnished by the Railroad Company(s), at the request of the Owner or its Contractor, will be at the Owner's or its Contractor's expense.

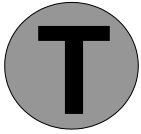

**MASSACHUSETTS BAY
TRANSPORTATION
AUTHORITY**

RAILROAD OPERATIONS DIRECTORATE



INSURANCE SPECIFICATIONS

The insurance outlined in these Specifications is required of the Owner or Contractor, and shall be provided by or in behalf of all subcontractors performing any portion of the work. The Owner or Contractor shall be responsible for any modifications, deviations or omissions of the required insurance as it applies to subcontractors.

All insurance policies, unless otherwise specified under Railroad Protective Liability Insurance, are to be written either on an occurrence basis or, if a claims-made form, applicable renewals must have a date retroactive to the construction start date and shall be maintained in force for one year following the acceptance of the work by the MBTA or its duly authorized representative.

With the exception of Railroad Protective Liability Insurance, all insurance policies must name the MBTA as an additional insured as its interest appears and waive any rights of subrogation against the MBTA.

Certificates of Insurance evidencing (1) either the claims-made or occurrence form coverage, (2) work description/location, (3) Owner or Contractor's corporate name, and (4) individual, company, government agency or municipality for which the work is being performed, are to be furnished to the MBTA prior to work commencement, and within fifteen (15) days of expiration of the insurance coverage, when applicable.

All policies must contain a minimum thirty (30) day written notice of cancellation clause, and provide that the Insurance Company shall notify the Owner, Contractor, MBTA and Railroad Company(s), via registered mail, of any cancellation, change or expiration of the policy.

Original Insurance Certificate(s) shall be received and approved by the MBTA before the Owner or Contractor will be allowed entry upon MBTA Railroad Property. Certificates, including any required endorsements, shall be furnished to the MBTA, c/o Risk Manager, Office of the Treasurer-Controller, Ten Park Plaza, Room 8450, Boston, MA 02116, and shall provide stated coverage and a provision that Notice of Accident (occurrence) and Notice of Claim shall be given to the Insurance Company as soon as practicable after notice to the insured(s).

Original Insurance Binders reflecting Railroad Protective Insurance shall be received and approved by the MBTA and the appropriate Railroad Company(s) prior to entry upon MBTA Railroad Property. Mailing addresses for transmittal of original Insurance Binders to the named insured Railroad Company(s) are contained on Page Four of these Specifications.

The Owner or Contractor shall indemnify, defend and save harmless the MBTA and the appropriate Railroad Company(s) from and against any and all liabilities, losses (including losses of revenue), claims, costs, damages and expenses (including reasonable attorney's fees and expenses) that may be asserted against or incurred by the MBTA and the Railroad Company(s) arising from or as a result of the Owner or Contractor's work, or its use of adjacent land. Said indemnification shall include claims, whether covered by insurance or not, including, but not limited to

Workers Compensation and similar insurance.

The Owner or Contractor shall maintain, during the life of the contract, from company (s) authorized to do business in the Commonwealth of Massachusetts and satisfactory to the MBTA:

A. COMMERCIAL GENERAL LIABILITY INSURANCE for personal injury, bodily injury and property damage in an amount not less than \$1,000,000 per occurrence and \$3,000,000 in the aggregate covering all work performed on over or adjacent to MBTA Railroad Property (the "work"), including:

1. All operations;
2. Contractual liability;
3. Coverage for the so-called "X, C, U" hazards, i.e., collapse of building, blasting, and damage to underground property;
4. Asbestos abatement, when applicable.

B. AUTOMOBILE LIABILITY INSURANCE including the use of all vehicles owned, non-owned, leased and hired, in an amount not less than \$1,000,000 combined single limit covering all the work.

C. WORKER'S COMPENSATION INSURANCE including Employees, Liability Insurance, as provided by Massachusetts General Laws, Chapter 152, as amended, covering all the work.

D. UMBRELLA LIABILITY COVERAGE in an amount not less than \$10,000,000 per occurrence covering all the work.

E. HAZARDOUS MATERIALS INSURANCE if the work involves hazardous materials, the following coverage is required:

1. **Pollution Liability insurance** for sudden and gradual occurrences in an amount not less than \$1,000,000 per occurrence and \$5,000,000 in the aggregate arising out of the work, including but not limited to all hazardous materials identified in the contract.
2. When applicable, the Owner or Contractor shall designate the disposal site and furnish a Certificate of Insurance from the Disposal Facility for Environmental Impairment Liability Insurance for (a) sudden and accidental occurrences in an amount not less than \$3,000,000 per occurrence and \$6,000,000 in the aggregate and (b) non-sudden occurrences in an amount not less than \$5,000,000 per occurrence and \$10,000,000 in the aggregate.

3. Certificates of insurance shall clearly state the hazardous materials exposure work being performed.

F. RAILROAD PROTECTIVE LIABILITY INSURANCE is specifically designed for insuring Railroads, and is purchased by the Owner or Contractor in the name of the MBTA and the Railroad Company(s). **The Railroad Company(s) is the named insured on the policy.** Railroad Protective Liability Insurance is required for any work performed within fifty (50) feet from center line of the nearest railroad track; it is not a substitute for any types of insurance outlined in these Specifications. Required limits are:

Bodily injury: not less than \$5,000,000 for all damages arising out of bodily injuries to or death of one person, and subject to that limit for each person, a total limit of \$6,000,000 for all damages arising out of bodily injury to or death of two or more persons in any one accident;

Property Damage: not less than \$10,000,000 or all damages arising out of injury to or destruction of MBTA property in any one accident, and subject to that limit per accident, a total of \$10,000,000 in the aggregate for all damages arising out of injury to or destruction of MBTA property.

Questions regarding insurance should be directed to MBTA's Risk Manager at (617) 222-3064.

Questions regarding train counts and train speeds should be directed to the appropriate Railroad Company(s) listed on Page Four.

PROOF OF INSURANCE

MAILING ADDRESSES:

MBTA

Risk Manager
c/o Treasurer-Controller
10 Park Plaza
Boston, MA 02116
cc: Massachusetts Realty Group

National Railroad Passenger Corporation (Amtrak)

Boston Division Office
c/o Division Engineer
2 South Station 5th Floor
Boston, MA 02110

CSX Transportation Inc.

500 Water St.
Jacksonville, FL 32202

Bay Colony Railroad Corporation

General Manager
4 Freight House Road
East Wareham, MA 02571

Boston and Maine Corporation
and Springfield Terminal Railway
Co.

Chief Engineer
402 Amherst Street
Suite 300
Nashua, NH 03063-1287

Providence and Worcester
Railroad Company

P. O. Box 1188
Worcester, MA 01601

Keolis Commuter Services

Chief Engineering Officer
470 Atlantic Ave.
Boston, MA 02110

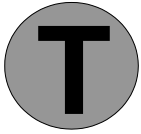

**MASSACHUSETTS BAY
TRANSPORTATION
AUTHORITY**

RAILROAD OPERATIONS DIRECTORATE

IV

PIPELINE OCCUPANCY SPECIFICATIONS

INDEX

<u>SUBJECT</u>	<u>PAGE</u>
<u>SECTION 1. GENERAL REQUIREMENTS</u>	
1.01 Description of Work and Location	1
1.02 License to Enter Railroad Company(s) Property	1
1.03 Work on Railroad Property	1
1.04 Coordination	3
1.05 Layout of Work	3
1.06 Indemnification	3
1.07 Scientific or Historic Artifacts	3
1.08 Record Documents	4
<u>SECTION 2. SUBMITTALS</u>	
2.01 Application for Occupancy	4
2.02 Submission of Construction Drawings and Specifications	4
<u>SECTION 3. TEMPORARY FACILITIES AND CONTROLS</u>	
3.01 Requirements of Regulatory Agencies	7
3.02 Installation and Coordination - General	7
3.03 Sanitary Facilities	8
3.04 Light and Power	8
3.05 Temporary Water	8
3.06 Temporary Traffic Controls	8

<u>SUBJECT</u>	<u>PAGE</u>
3.07 Temporary Work and Storage Areas	8
3.08 Pollution Abatement Controls	9
3.09 Protection of Persons and Properties	10
3.10 Vermin Control	11
3.11 Rubbish and Debris Removal	11
SECTION 4. <u>PIPELINE OCCUPANCY GENERAL CRITERIA</u>	
4.01 Method of Installation	12
4.02 General Requirements	13
4.03 Inspection and Testing	14
4.04 Cathodic Protection	14
4.05 Soil Investigations	15
4.06 Ground Stabilization	16
4.07 Support of Tracks	16
4.08 Geotechnical Monitoring	17
4.09 Pipelines On Bridges	18
4.10 Bonding and Grounding of Pipelines In Electrified Territory	18
4.11 Abandoned Pipelines or Facilities	19
4.12 Drainage	19
SECTION 5. <u>CARRIER PIPE</u>	
5.01 Design Criteria - General	20
5.02 General - Products	20

5.03	Oil and Gas Pipes	21
5.04	Cast Iron Pipe	21
5.05	Vitrified Clay Pipe	21
5.06	Corrugated Metal Pipe	21
5.07	Asbestos Cement Pipe	21
5.08	Other	22
5.09	Shut-Off Valve	22
5.10	Signs	22
5.11	Installation - Execution	22

SECTION 6. CASING PIPE

6.01	Design Criteria - General	23
6.02	Protection at Ends of Casing	24
6.03	Vents	24
6.04	Steel Pipe - Products	25
6.05	Cast Iron Pipe	25
6.06	Corrugated Metal Pipe and Corrugated Structural Plate Pipe	25
6.07	Reinforced Concrete Pipe	25
6.08	Tunnel Liner Plates	25
6.09	Depth of Installation - Execution	26
6.10	Method of Installation	26
6.11	Construction	27

<u>PLATES</u>	<u>PAGE</u>
Plate I Pipe Crossing	33
Plate II Pipe Crossing	34
Plate III Longitudinal Occupancy	35
Plate IV Pipe Crossing Data Sheet	35
Plate V Table of Minimum Wall Thickness	37

SECTION 1. GENERAL REQUIREMENTS

1.01 DESCRIPTION OF WORK AND LOCATION

These specifications apply to the design and construction of pipelines carrying flammable and non-flammable substances and to casings over 4-inches in diameter containing wires and cables, under, across or along MBTA Railroad Property, facilities and tracks.

1.02 LICENSE TO ENTER RAILROAD PROPERTY

- A. Entry upon MBTA Railroad Property for the purpose of conducting surveys, field inspections, obtaining soil information, or any other purpose associated with the design and engineering of the proposed occupancy, will be authorized by an MBTA License for Entry (See "Guidelines and Procedures for Construction on MBTA Railroad Property").
- B. Issuance of the License does not constitute authority to proceed with the actual construction.

1.03 WORK ON RAILROAD PROPERTY

- A. The safety and continuity of train operations shall be the first priority. The Applicant shall arrange the work so that the trains will be protected and safeguarded at all times. Whenever the work may affect the safety and movement of trains, the method, sequence and time schedule of performing such work shall be submitted to the Director of Engineering for MBTA Railroad Operations or their authorized representative for approval.
- B. The Applicant waives all claims against the Railroad Company(s) and/or the MBTA for delays or any interference occasioned by railroad traffic or railroad maintenance.
- C. All Applicant-designed temporary construction on MBTA Railroad Property shall be designed in accordance with the appropriate railroad criteria and all construction performed on, over, under, within or adjacent to MBTA Railroad Property will be subject to the inspection and approval of the Railroad Company(s) and/or MBTA.
- D. A minimum of fourteen (14) days advance written notice shall be given to the Railroad Company(s) prior to construction related activities.
- E. The Railroad Company(s) will furnish such qualified flagmen, signalmen or protection men as may be required to insure complete

protection of train operations and railroad facilities. The need for this type of service will be determined by the Railroad Company(s) on the basis of railroad regulations and the Applicant's approved construction schedule. No work shall proceed without proper protection on the site.

- F. All expenses incurred in connection with protection of railroad facilities by Railroad Company(s) employees will be borne by the Applicant. Billings for such service or expense, including labor, materials and equipment will be made directly to the Applicant for payment.
- G. During construction, railroad traffic shall be maintained at all times without interruption, except when approved in advance, in writing, by the Director of Engineering for MBTA Railroad Operations or their authorized representative.
- H. All construction operations shall be conducted so as not to interfere with, interrupt, or endanger the operation of trains, nor damage, destroy, or endanger the integrity of railroad facilities. All work on or near MBTA Railroad Property shall be conducted in accordance with the Railroad safety rules and regulations. The Applicant shall secure and comply with the Railroad safety rules and shall give written acknowledgment to the Railroad Company(s) that they have been received, read, and understood by the Applicant and their employees. Construction operations will be subject to Railroad Company(s) inspection at any and all times.
- I. All cranes, lifts, or other equipment that will be operated in the vicinity of the MBTA's electrification and power transmission facilities shall be electrically grounded as directed by the Railroad Company(s).
- J. At all times when the work is progressing, a field supervisor for the work with no less than twelve (12) months experience in the operation of the equipment being used shall be present. Certification of the above must be submitted to the Railroad Company(s).
- K. Whenever equipment or personnel are working closer than fifteen (15) feet to the closest rail of an adjacent track, that track shall be considered as being obstructed. As best possible, all construction operations shall be conducted no less than this distance. Construction operations closer than fifteen (15) feet to the closest rail of a track shall be conducted only with the permission of, and as directed by, a qualified Railroad Company(s) employee present at the work site.
- L. Crossing of tracks at grade by equipment and personnel is prohibited except by prior arrangement with, and as directed by, the Director of

Engineering for MBTA Railroad Operations or their authorized representative.

- M. All tunneling, jacking and boring operations within railroad influence lines will be done on a 24 hour per day basis to minimize Railroad exposure to construction hazards.

1.04 COORDINATION

The Applicant shall coordinate the work with their Contractors, subcontractors, utility companies, governmental units, and any affected Railroad Company(s) with regard to site access, establishment and use of temporary facilities, work schedules, and other elements of the specified work which require interfacing with others.

1.05 LAYOUT OF WORK

The Applicant shall lay out their work true to lines and grades indicated on the Drawings and shall be responsible for all measurements in connection therewith. The Applicant will be held responsible for the execution of the work to such lines and grades indicated on the approved construction Drawings or such other lines and grades as may be directed or established by the Director of Engineering for MBTA Railroad Operations or their authorized representative.

1.06 INDEMNIFICATION AND INSURANCE

See requirements in "Guidelines and Procedures for Construction on MBTA Railroad Property" and "Insurance Specifications."

1.07 SCIENTIFIC OR HISTORIC ARTIFACTS

The Applicant shall immediately notify the Director of Engineering for MBTA Railroad Operations of the discovery of scientific or historical artifacts and shall protect same until identified and removed by the appropriate Authorities exercising jurisdiction.

1.08 RECORD DOCUMENTS

- A. The Applicant shall furnish the Railroad Company(s) and the MBTA with one reproducible "As Built" copy of each approved Construction Drawing, marked to indicate all changes and deviations from same.
- B. All project record documents shall be received and accepted by the MBTA and the Railroad Company(s) prior to final inspection.

SECTION 2. SUBMITTALS

2.01 APPLICATION FOR OCCUPANCY

The Applicant must agree, upon approval of the construction details by the Director of Engineering for MBTA Railroad Operations, to execute the MBTA Pipeline Occupancy Agreement and pay any required fees and/or rentals outlined therein. Refer to "Guidelines and Procedures for Construction on MBTA Railroad Property" for application policy.

2.02 SUBMISSION OF CONSTRUCTION DRAWINGS AND SPECIFICATIONS

- A. Six (6) sets of Drawings and specifications for proposed pipeline occupations shall be submitted to the AGM for Real Estate and Asset Development and meet the approval of the Railroad Company(s) and the MBTA prior to the start of construction. These plans are to be prepared in sizes as small as possible and are to be folded to an 8-1/2 inch by 11-inch size (folded dimensions) with a 1-1/2 inch margin on the left side and a 1-inch margin on the top.
1. After folding, the title block and other identification of the Drawings shall be visible at the lower right corner, without the necessity of unfolding. Each Drawing shall bear an individually identifying number and an original date, together with subsequent revision dates, clearly identified on the Drawing.
 2. All Drawings are to be individually folded or rolled and where more than one Drawing is involved, they shall be assembled into complete sets before submission to the MBTA.
- B. Drawings shall be to scale and show the following (see attached Plates).
1. Plan view of proposed pipeline in relation to all railroad facilities.
 2. Location of pipe (in feet) from nearest railroad milepost, centerline of a railroad bridge (giving bridge number), or centerline of an existing or former passenger station, or other fixed point. In all cases, the name of the City or Town and County in which the proposed facilities are located must be shown.
 3. Profile of ground on centerline of pipe from field survey showing relationship of pipe and casing to ground level, tracks and other facilities. For longitudinal occupations, the profile of adjacent track(s) must be shown.

4. All MBTA property lines. If pipeline is in a public highway, the limits of the right-of-way for the highway shall be clearly indicated with dimensions from centerline.
 5. The angle of crossings in relation to centerline of tracks.
 6. Location of valves or control stations of the pipeline.
 7. "Pipe Crossing Data Sheet" completed and out on Plan.
- C. The Drawing must be specific (both on MBTA Railroad Property and under tracks that are not on MBTA Railroad Property) as to:
1. Method of installations.
 2. Size and material of casing pipe.
 3. Size and material of carrier pipe.

These items shall not have an alternative.

- D. Once an application is approved by the Director of Engineering for MBTA Railroad Operations or their authorized representative, proposed variances from the approved plans, specifications, method of construction, etc., will be resubmitted for approval.
- E. Location and dimensions of jacking, boring, or tunneling pits shall be shown with details of their sheeting and shoring. If the bottom of the pit excavation nearest the adjacent track intersects a line from a point 5.5 feet horizontally from center line of adjacent track at the plane of the base of fall drawn on a slope of 2 horizontal to 1 vertical, submit design and details of the pit construction to the MBTA for approval complete with computations prepared by a Registered Professional Engineer. In any event, the face of the pit shall be no less than 25 feet from adjacent track, unless otherwise approved by the Director of Engineering for MBTA Railroad Operations or their authorized representative. Pits shall be fenced, lighted, and otherwise protected as directed by the Railroad Company(s).
- F. All Drawings and computations, including those submitted by Contractors, must bear the seal of a Registered Professional Engineer.
- G. Computations for all structures involving the support or protection of railroad track, embankment and facilities must be prepared by and bear the seal of a Registered Professional Engineer and shall be submitted within the construction Drawings.
- H. When computer calculations are included with design calculations, the following documentation shall be furnished:

1. A synopsis of the computer program(s) stating briefly required input, method of solution, approximations used, second order analysis incorporated, specifications or codes used, cases considered, output generated, extent of previous usage of certification of program(s) and program(s) author.
 2. Identification by number, indexing and cross-referencing of all calculation sheets, including supplemental "long-hand" calculation sheets.
 3. Fully identified, dimensioned, and annotated diagram of each member or structure being considered.
 4. Clear identification and printing of all input and output values, including intermediate values if such values are necessary for orderly review.
 5. Identification of the processing unit, input/output devices, storage requirements, etc., if such supplemental information is significant and necessary for evaluation of the submittal.
- I. Specifications shall conform to Construction Specifications Institute (CSI) 16 Division, 3-part Section Format.
- J. If other than American Railway Engineering Association (AREA), American Society for Testing and Materials (ASTM), or American National Standards Institute (ANSI) specifications are referred to for design, materials or workmanship on the Construction Drawings and specifications for the work, then copies of the applicable sections of such other specifications referred to shall accompany the Construction Drawings and specifications for the work.

SECTION 3. TEMPORARY FACILITIES AND CONTROLS

3.01 REQUIREMENTS OF REGULATORY AGENCIES

Applicant shall:

- A. Obtain and pay all costs for required permits for installation and maintenance of temporary facilities and controls.
- B. Comply with all applicable Federal, State and local codes, regulations and ordinances.
- C. Comply with regulations and requirements of all utility or service companies from which temporary utilities or services are obtained, and pay all costs incurred therewith.

3.02 INSTALLATION AND COORDINATION - GENERAL

Applicant shall:

- A. Install all temporary facilities and controls in a neat and orderly manner.
- B. Make all temporary facilities structurally and functionally sound throughout.
- C. Construct temporary facilities and controls to give continuous service and to provide safe working conditions.
 - 1. Enforce conformance with applicable standards
 - 2. Enforce safe practices.
- D. Modify, extend or relocate temporary facilities and controls as work progress requires.
- E. Locate temporary facilities and controls to avoid interference with, or hazards to:
 - 1. Work or movement of railroad personnel or traffic.
 - 2. Vehicular traffic.
 - 3. General Public.
 - 4. Work of other contracts.
 - 5. Railroad Passengers.
- F. Obtain easements as may be required across non-MBTA Railroad Property.
- G. Provide materials for temporary facilities and controls for the purpose intended and shall not violate requirements of applicable codes and shall not create unsafe conditions.

3.03 SANITARY FACILITIES

Prior to the start of work, the Applicant shall furnish necessary toilet conveniences, secluded from public observation. They shall be kept in a clean and sanitary condition and comply with the requirements and regulations of the area in which the work is performed.

3.04 LIGHT AND POWER

Applicant shall make their own arrangements for obtaining temporary light and power as required for the work, and shall maintain such temporary facilities in a proper and safe condition, including compliance with applicable codes.

3.05 TEMPORARY WATER

Applicant shall make their own arrangements for obtaining all temporary water service as required for the work.

3.06 TEMPORARY TRAFFIC CONTROLS

Applicant shall cooperate with the directives of the MBTA and/or Railroad Company(s) regarding vehicular traffic control and provide any temporary controls or devices required to eliminate or minimize congestion or obstruction of vehicular traffic caused by the work, including use of designated routes of ingress and egress from the work area.

3.07 TEMPORARY WORK AND STORAGE AREAS

- A. The areas designated by the MBTA as the temporary parking, work and storage area(s) will be provided to the Applicant in accordance with the terms of the MBTA License Agreement.
- B. All designated temporary parking, work and storage areas used by the Applicant shall be restored to their original condition prior to completion of the work, subject to inspection and approval of the MBTA and the Railroad Company(s).

3.08 POLLUTION ABATEMENT CONTROLS

Applicant shall:

- A. Conduct operations in a manner to minimize pollution of the environment surrounding the area of work by every means possible. Specific controls shall be provided as follows:
 - 1. Vehicles: All vehicles and material transport trucks leaving the site and entering paved public streets shall be cleaned of mud and dirt clinging to the body and wheels of the vehicle. Trucks arriving at or leaving the site with materials shall be loaded in a manner which will prevent dropping of materials or debris on the streets. Spills of materials in public areas shall be removed immediately at no cost to the MBTA or Railroad Company(s).

2. Waste Materials: No waste or erosion materials shall be allowed to enter natural or man-made water or sewage removal systems. Erosion materials from excavations, borrow areas or stockpiled fill shall be contained within the work area. The Applicant shall develop methods for control of waste and erosion which shall include such means as filtration, settlement and manual removal to satisfy the above requirements. Do not dispose of machinery lubricants, fuels, coolants and solvents on the site. If hazardous waste is encountered, the Applicant shall dispose of it in accordance with all federal, state and local codes. Verification of proper disposal must be provided, in writing, to the MBTA and the Railroad Company(s).
 3. Burning: No burning of waste shall be allowed without prior written permission. In cases where permission is granted, burning shall be conducted in accordance with the regulations of the appropriate jurisdictional agency.
 4. Dust Control: The Applicant shall at all times control the generation of dust by their operations. Control of dust is mandatory and shall be accomplished by water sprinkling or by other methods approved by the MBTA or Railroad Company(s).
 5. Noise Control: The Applicant shall take every action possible to minimize the noise caused by their operation. When required by agencies having jurisdiction, noise producing work shall be performed during less sensitive hours of the day or week as directed by the MBTA or Railroad Company(s) or as required by local ordinance.
 6. Environmental: All local and state environmental laws will be strictly adhered to. All applications, permits, licenses, approvals, etc., will be the sole responsibility of the Applicant.
- B. Submit a program for pollution control with applicable licenses and permits for all piping carrying non-potable liquids, gases or other pollutants.

3.09 PROTECTION OF PERSONS AND PROPERTY

A. Safety Requirements

1. The Applicant must adhere to the most stringent provisions of the applicable statutes and regulations of the political subdivision in which the work is being performed. The Applicant must also observe the Department of Labor-

Occupational Safety, Health Administration provision, pertaining to the safe performance of the work, and further, the methods of performing the work must not involve undue danger to the personnel employed thereon, Railroad Company(s) employees, the public, or to public and private property. Should charges of violation of any of the above be issued to the Applicant in the course of the work, a copy of each charge shall immediately be forwarded to the Railroad Company(s). The Applicant shall pay all fines and penalties levied against him.

2. The Applicant shall erect and maintain, as required by existing conditions and progress of the work, all reasonable safeguards for safety and protection. This includes posting danger signs and other warnings against hazards, promulgating safety regulations and notifying owners and users of adjacent utilities.

B. Safety of Persons and Property - The Applicant shall take all reasonable precautions for the safety of, and shall provide all reasonable protection to prevent damage, injury or loss to:

1. All employees on the work site and all other persons who may be affected.
2. All materials and equipment, whether in storage on or off the site, under the care, custody or control of the Contractor or any of their subcontractors.
3. Other property at the site or adjacent thereto, including walks, pavements, roadways, structures, and utilities not designated for removal, relocation or replacement in the course of construction. Any damage to such items shall be restored to original condition by the Applicant at no cost to the MBTA or Railroad Company(s).

C. First Aid

The Applicant shall maintain adequate first aid supplies at the site as prescribed by Federal, State or Local codes and regulations.

D. Use of Explosives

Non blasting methods are preferred. See "Blasting Specifications."

E. Site Security

The Applicant shall:

1. Maintain a secure work site protecting the MBTA and the Railroad Company(s) interests and property from claims arising from trespass, theft and vandalism.
2. Permit access to the work site only to employees, Contractors and those persons having business related to the work.
3. Provide security measures as required to protect Contractor or subcontractor's tools, equipment and property from damage, theft or vandalism.
4. Assume all costs for any MBTA and/or local police details required by the work.

3.10 VERMIN CONTROL

- A. Do not permit food scraps, lunch bags, food wrappers or other items which would attract rats or other vermin to be left lying around the site. Deposit such items in closed, rat-proof metal containers for disposal on a regular basis.
- B. The Applicant must provide vermin control as required by the MBTA or Railroad Company(s).

3.11 RUBBISH AND DEBRIS REMOVAL

- A. Rubbish and debris resulting from the work must be neatly piled in a single location and legally disposed of at least once a week. If rubbish or debris interferes with railroad activities, or creates a fire or safety hazard, it must be removed on a more frequent basis.
- B. Volatile waste such as mineral spirits, oil, or paint thinner shall not be disposed of in storm or sanitary drains, streams or waterways or any location upon the site.

SECTION 4. PIPELINE OCCUPANCY GENERAL CRITERIA

GENERAL:

4.01 METHOD OF INSTALLATION:

- A In a public way:
 1. No work shall be done without a Railroad Company(s) Inspector present.
 2. Open cuts will not be allowed in or immediately adjacent to an at

grade crossing. Sleeves will be installed by the jerking method, unless otherwise approved by the Director of Engineering for MBTA Railroad Operations.

3. Jerking is the preferred method of installation in or immediately adjacent to and at grade crossing. The sleeve may be installed by the open cut method with the Applicant paying for the complete rebuilding of the crossing, pending approval of the Director of Engineering for MBTA Railroad Operations. Approval will be given only under very unusual circumstances.
4. Jacking is the preferred method of installation in or immediately adjacent to and at grade crossing scheduled for rebuilding. The sleeve may be installed by the open cut method within seven (7) calendar days of the scheduled date of the crossing reconstruction. In the case of any open cut, strict adherence shall be made to the backfill specifications which provide the MBTA with written certification from a testing lab or Professional Engineer, that the backfill density requirements of the MBTA specifications have been met or exceeded.

B. Not within a Public Way:

The preferred method of crossing the railroad is by jacking of a pipe sleeve under the railroad. Only upon written request, will an alternate of open cut be given consideration. The engineering decision shall be based upon, but not limited to, the following: (1) track usage, (2) depth of cut, (3) soil conditions, (4) physical restraints. In the event an open cut is allowed, the following items shall be adhered to, and (5) any other circumstances which may necessitate an open cut.

1. The installation is to be a continuous operation and performed according to an MBTA approved schedule.
2. No work shall be done without a Railroad Company(s) Inspector present.
3. MBTA backfill specifications by the Owner or its Contractor.
4. The Owner or its Contractor may be required to provide a non-refundable lump sum payment for "after the fact maintenance." The determination of this amount is based on the individual situation. No work will be allowed until this payment is received. This payment is not to be confused with payments for Drawings and specification review, flagging, inspection, etc. (also required from the Owner or its Contractor before they enter upon MBTA property.)

4.02 GENERAL REQUIREMENTS

- A. Pipelines under or across MBTA tracks on rights-of-way shall be encased in a larger pipe or conduit called the casing pipe as indicated in Plate II.
- B. Casing pipe will be required for all pipelines carrying oil, gas, petroleum products, or other flammable, highly volatile substances which, from their nature or pressure, might cause damage if escaping on or near MBTA Railroad Property.
- C. For non-pressure sewer or drainage crossings where the installation can be made without interference to railroad operations, the casing pipe may be omitted when the pipe strength is capable of withstanding railroad loading. This type of installation must be approved by the Director of Engineering for MBTA Railroad Operations.
- D. The casing pipe shall be laid across the entire width of the right-of-way. Casing pipe shall extend beyond the right-of-way when the right-of-way line on either side of the tracks is less than the minimum length of casing specified in Section 6, Para. 6.01(E).
- E. Pipelines laid longitudinally on railroad right-of-way shall be located in accordance with Plate III. If located within 25 feet of the closest rail of any track or closer than 45 feet to nearest point of any bridge, building or other structure, the carrier pipe shall be encased.
- F. Where practicable, pipelines shall be located to cross the tracks at approximate right angles, but preferably at not less than 45 degrees.
- G. Pipelines shall not be placed within a culvert, under railroad bridges, or closer than 45 feet to any portion of a railroad bridge, building, or other structure, except in special cases, and then by special design, as approved by the Director of Engineering for MBTA Railroad Operations.
- H. Pipelines carrying liquefied petroleum gas shall, where practicable, cross the railroad where tracks are carried on embankment.
- I. Any replacement or modification of an existing carrier pipe and/or casing shall be considered a new installation, subject to the requirements of these Specifications.
- J. Where laws or orders of public authority prescribe a higher degree of protection than specified herein, the higher degree so prescribed shall be deemed a part of these Specifications.

- K. Pipelines and casings shall be suitably insulated from underground conduits carrying electric wires on MBTA Railroad Property.

4.03 INSPECTION AND TESTING

For pipelines carrying flammable or hazardous materials, ANSI Codes B 31.8 and B 31.4, current at time of constructing the pipeline, shall govern the inspection and testing of the facility on MBTA Railroad Property, except that proof-testing of strength of carrier pipe shall be in accordance with the requirements of ANSI Code B 31.4, as applicable, for all pipelines carrying all liquefied petroleum gas, natural or manufactured gas, and other flammable substances.

4.04 CATHODIC PROTECTION

- A. Cathodic protection shall be applied to all pipelines and casings carrying flammable substances.
- B. Where casing and/or carrier pipe is cathodically protected by other than anodes, the Director of Engineering for MBTA Railroad Operations shall be notified and suitable testing shall be made. This testing shall be witnessed by the Railroad Company(s) to insure that other railroad structures and facilities are adequately protected from the cathodic current in accordance with the recommendations of Reports of Correlating Committee on Cathodic Protection, current issue by the National Association of Corrosion Engineers.

4.05 SOIL INVESTIGATIONS

- A. Soil borings (or other soil investigations approved by the Railroad Company(s)) will be performed to determine the nature of the underlying material for all pipe crossings under tracks. See Test Boring Specifications.
- B. Borings shall be made on each side of the tracks, on the centerline of the pipe crossing, and as close to the tracks as practicable.
- C. Soil borings shall be in accordance with the current issue of the American Railway Engineering Association Specifications, Chapter 1, Part 1, "Specifications for Test Borings". Soils shall be investigated by the split-spoon and/or thin-walled tube method and rock shall be investigated by the Boring method specified therein.
- D. Soil boring logs shall clearly indicate all of the following:
 - 1. Boring number as shown on boring location Drawing.

2. Elevation of ground at boring, using same datum as the pipeline Construction Drawings.
 3. Description or soil classification of soils and rock encountered.
 4. Elevations or depth from surface for each change in strata.
 5. Identification of where samples were taken and percentage of recovery.
 6. Location of ground water at time of sampling and, if available, subsequent readings.
 7. Natural dry density in lbs./sq.ft. for all strata.
 8. Unconfined compressive strength in tons/sq.ft., for all strata.
 9. Water content (percent). Liquid limit (percent) and plastic limit (percent).
 10. Standard penetration in blows/ft.
- E. The location of the carrier pipe and casing shall be superimposed on the boring logs before submission to the Director of Engineering for MBTA Railroad Operations.
- F. Soil investigation by auger, wash, or rotary drilling method is not acceptable.
- G. Soil boring logs shall be accompanied by a Drawing drawn to scale showing location of borings in relation to the tracks and the proposed pipe location, the elevation of around surface at each boring, and the elevation of the base of rail of the tracks.

4.06 GROUND STABILIZATION

Soil stabilization shall take place prior to the start of jacking. Stabilization shall be achieved by dewatering, grouting or a combination of both to maintain the stability of the face of the heading.

- A. The Owner or its Contractor shall lower and maintain the ground water level a minimum of two (2) feet below the invert at all times during construction by well points, vacuum well points, or deep wells to prevent inflow of water and/or soil into the heading. Ground water observation wells shall be installed in the area to be dewatered to demonstrate that the dewatering requirements are being complied with.
- B. The grouting Contractor shall be a specialist in the field with a minimum

of five (5) continuous years of successfully grouting soils. All granular soils (silty sands, sand or sand and gravel) shall be stabilized by injection of a cement or chemical grout from the ground surface or from the pipe heading. The stabilization shall extend as far as necessary outside the periphery of the casing pipe in order to maintain a stable face at the heading.

- C. Railroad Company(s) forces will survey the crossing prior to, during and after construction. If it is necessary to align or surface the tracks as a result of construction, the Railroad Company(s) will perform the work at the expense of the Owner or the Owner's Contractor.

4.07 SUPPORT OF TRACKS

- A. When jacking, boring, or tunneling, temporary track support structures shall be installed. The track support structures shall be provided by the Applicant and installed by the Railroad Company(s) at the Applicant's expense. The Contractors proposed type of temporary track support structures shall be subject to the approval of the Railroad Company(s)'
- B. All work involving rail, signals, ties and other track material will be performed by the Railroad Company(s) at the Applicant's expense.
- C. The Applicant shall deliver the track support structures to a site approved by the Railroad Company(s). Provisions for unloading shall be provided by the Applicant at no expense to the Railroad Company(s) and the Applicant shall provide the necessary labor to handle the material for pre-installation inventory.

4.08 GEOTECHNICAL MONITORING

THE FOLLOWING SPECIFICATIONS ARE REQUIRED FOR ALL PIPE JACKING OPERATIONS.

- A. Jacking shall be performed on a continuous basis, 24 hours per day, and 7 days per week.
- B. The monitoring points shall be set up one week before the jacking operation begins. The MBTA and Railroad Company(s) shall be notified. Elevation readings shall begin two days prior to the start of jacking and continue for a minimum of two weeks after the completion of the jacking operation. Initial readings immediately after any surfacing operations shall serve as new baseline figures. All future elevation readings shall be compared to the adjusted baseline. If the

track deviates to a condition not acceptable to the MBTA or Railroad Company(s), corrections shall be made at the proponent's expense.

- C. Elevation readings shall be taken from the top rail of each track.
- D. Elevation readings shall be taken every four hours or two times per shift, i.e., six times per day. The readings shall be faxed to the MBTA and Railroad Company(s) on a daily basis and all information is to be presented in legible print. Additional readings may be required by the MBTA or Railroad Company(s).
- E. Stations shall be spaced at 15-1/2 foot intervals. The number of stations required shall be determined by the depth of the pipe. There shall be a minimum of two stations on either side of the centerline jacking. Additional stations may be required at the discretion of the MBTA or Railroad Company(s),
- F. Elevation readings must show the date, time, weather conditions and temperature. Each reading must also provide the following information: track number, compass direction, station number, base elevation (with date), static elevation, change in elevation (recorded in hundredths and in inches), dynamic reading and total deflection in inches. See sample sheet attached.
- G. Station "0" shall be located at the centerline of the pipe jacking with Stations 1 and being to the right and Stations -1 and -2 being to the left when standing in the gauge of the near track and looking at the receiving pit. In multiple track areas the stations as determined herein are to be carried across each track perpendicular to the near track.
- H. Elevation readings taken from the top of the rail for static measurement and the dynamic readings shall be combined and the sum compared to the adjusted baseline. This reading will demonstrate the difference in elevation caused by the jacking operation.
- I. The MBTA requires that the truck be maintained at all times within established criteria for the specific track classification. At the completion of the project the requirement for tamping and realigning the tracks, caused by the settlement from the construction activity, remains with the Contractor for the duration as specified by the MBTA in their initial review of the work plans. This tamping and track realignment will be performed by the MBTA or Railroad Company(s) at the sole expense of the Contractor.

4.09 PIPELINES ON BRIDGES

- A. Pipelines carrying flammable or non-flammable substances which by their nature might cause damage if escaping on or near railroad facilities or personnel shall not be installed on bridges over railroad tracks or bridges carting railroad tracks.
- B. The Director of Engineering for MBTA Railroad Operations may approve such an installation when it is demonstrated that no practicable alternative is available.
- C. When allowed by the Director of Engineering for MBTA Railroad Operations, pipelines on bridges shall be located in a way to minimize the possibility of damage from vehicles, railroad equipment, vandalism and other external causes. Pipelines on bridges may be installed in a utility bay that is constructed between the girders of the bridge. The utility bay shall be protected from the environment by a removable shield bolted to the girders. This will allow utility companies to comply with the Code of Federal Regulations for Periodic Inspection.
- D. In the event of pipe relocation due to the reconstruction of a bridge, the installation of the new pipe must comply with the requirements in these Specifications.

4.10 BONDING AND GROUNDING OF PIPELINES IN ELECTRIFIED TERRITORY

- A. Carrier pipe shall be enclosed in a metal casing that is isolated from carrier pipe by approved insulators having a dielectric value of not less than 25 kV that provide an air gap between carrier pipe and casing of not less than 2 inches.
- B. Carrier pipe supporting hangers, mountings or cradles shall provide an insulation value of not less than 25 kV and an air gap of not less than 2 inches between casing and any portion of mounting assembly.
- C. Any grounding or isolation methods used must have a minimum dielectric of 25,000 volts.

4.11 ABANDONED PIPELINES OR FACILITIES

- A. For all pipeline occupations on the railroad right-of-way, the owner of the pipeline shall notify the MBTA, in writing, of the intention to abandon the pipeline. Upon abandonment the carrier pipe shall be removed and the casing shall be filled with cement grout, compacted sand or other material approved by the Director of Engineering for

MBTA Railroad Operations. If it is impractical to remove the carrier pipe, then the carrier must be filled along with the annular space between the casing and carrier.

- B. Facilities other than pipelines shall be removed or altered at abandonment to the satisfaction of the Director of Engineering for MBTA Railroad Operations.

4.12 DRAINAGE

- A. Occupancies shall be designed, and constructed, so that adequate and uninterrupted drainage of railroad right-of-way is maintained. If it becomes necessary to block a ditch, pipe or other drainage facility, the applicant shall install temporary pipes, ditches or other drainage facilities as required to maintain adequate drainage, as approved by the MBTA or Railroad Company(s). Upon completion of the work, the temporary drainage facilities shall be removed and the permanent facilities restored.
- B. Water may not be pumped or disposed of onto railroad rights-of-way unless discharged into an existing drainage facility, providing discharge does not cause erosion or leave sediment.
- C. When water runoff is disposed of onto MBTA Railroad Property, it must be demonstrated to the Railroad Company(s) that the existing drainage facility can accommodate the increased runoff. Drainage calculations stamped by a Registered Professional Engineer must accompany all requests to use railroad culverts or drainage ditches.
- D. If in the estimation of the Director of Engineering for MBTA Railroad Operations or their authorized representative, the railroad culvert or drainage ditch has to be cleaned in order to allow the increased flow to safely pass through the culvert, it must be cleaned at the expense of the applicant.

SECTION 5. CARRIER PIPE

GENERAL:

5.01 DESIGN CRITERIA

- A. If the maximum allowable stress in the carrier pipe on either side of the occupancy of MBTA Railroad Property is less than specified herein, the carrier pipe on MBTA Railroad Property shall be designed at the same stress as the adjacent carrier pipe.

- B. Requirements for carrier pipe under railroad tracks shall apply for a minimum distance equal to that of the casing pipe.
- C. Carrier pipes within a casing shall be designed for railroad live loads as if they were not encased.
- D. All pipes, ditches and other structures carrying surface drainage on MBTA Railroad Property and/or crossing under railroad tracks shall be designed to carry the run-off from a one hundred (100) year storm. Computations indicating this design and suitable topographic plans, prepared by a Registered Professional Engineer, shall be submitted to the Director of Engineering for MBTA Railroad Operations, or their authorized representative, for approval. If the drainage is to discharge into an existing drainage channel on railroad right-of-way and/or under railroad tracks, the computations should include the hydraulic analysis of any existing structures. Submitted with the computations should be formal approval of the proposed design by the appropriate governmental agency.

PRODUCTS:

5.02 GENERAL

- A. All pipes shall be designed for the external and internal loads to which they will be subjected. The dead load of earth shall be considered 120 pounds per cubic foot. Railroad live loading shall be Cooper's E-80 with 50% added for impact. On railroad right-of-way or where railroad loading will be experienced, the following shall be the minimum requirements for carrier pipes:
 - 1. Reinforced concrete pipe - ASTM Spec. C-76, Class V, Wall C.
 - 2. Ductile Iron Pipe - For Culverts and Gravity Sewers - ASTM Spec, A-142 Extra Heavy.

5.03 OIL AND GAS PIPES

- A. Pipelines carrying oil, liquefied petroleum gas, natural or manufactured gas and other flammable products shall conform to the requirements of the current ANSI B 31.4, with Addenda, "Liquefied Petroleum Transportation Piping Systems," ANSI B 31.8, "Gas Transmission and Distribution Piping Systems," and other applicable ANSI codes, except that the minimum allowable stresses for the design of steel pipe shall not exceed the following percentages of the specified minimum yield strength (multiplied by the longitudinal joint factor) of the pipe as defined in the ANSI Codes:

1. Steel pipe within a casing under, across and longitudinally on MBTA Railroad Property. (The following percentages apply to hoop stress):
 - a. Seventy-two percent for installation on oil pipelines.
 - b. Fifty percent for pipelines carrying liquefied petroleum gas and other flammable Liquids with low flash point.
 - c. Sixty percent for installations on gas pipelines.
 2. Steel pipe without a casing laid longitudinally on MBTA Railroad Property. (The following percentages apply to hoop stress):
 - a. Sixty percent for installations on oil pipelines.
 - b. Forty percent for pipelines carrying liquefied petroleum gas and other flammable Liquids with low flash point.
 - c. Forty percent for installations on gas pipelines.
- B. Design computations showing compliance with the requirements of Paragraph 5.03(A) above, and prepared by a Registered Professional Engineer, shall accompany the application for occupancy.
- 5.04 CAST IRON PIPE: For water and other materials under pressure shall conform to the current ANSI specifications A-21 Series 21/45 Iron strength with plain end, compression type or mechanical joints. The strength to sustain external railroad and other loadings shall be computed in accordance with the current ANSI A-21.1 "Thickness Design of Cast Iron Pipe."
- 5.05 VITRIFIED CLAY PIPE: ASTM Spec C-700, Extra Strength.
- 5.06 CORRUGATED METAL PIPE: AREA Spec Chapter I, Part 4
- 5.07 ASBESTOS CEMENT PIPE (Non-pressure): ASTM Spec. C-428, C1. 5000 Min. Pressure: AWWA Spec. C400, C1. 150 Min.
- 5.08 OTHER: Other miscellaneous piping not specified above shall be submitted to approval by the Director of Engineering for MBTA Railroad Operations.
- 5.09 SHUT-OFF VALVE
- A. Provide accessible emergency shut-off valves at each side of the railroad within distances and at locations as directed by the Chief Engineering Officer.

- B. Where pipelines are provided with automatic control stations and within distances approved by the Director of Engineering for MBTA Railroad Operations, no additional valves will be required.

5.10 SIGNS

- A. Prominently identify all pipelines at rights-of-way by durable, weatherproof signs located over the centerline of the pipe. Mark pipelines at under crossings on both sides of track. Signs shall display the following:
 - 1. Name and address of pipeline Owner.
 - 2. Contents of Pipe.
 - 3. Pressure in Pipe.
 - 4. Depth below grade at point of sign.
 - 5. Emergency telephone in event of pipe rupture.
 - 6. Railroad File Number.
- B. For pipelines running longitudinally on MBTA Railroad Property, place signs over the pipe (or offset and appropriately mark) at all changes in direction the pipeline. Locate signs so that when standing at one sign, the next adjacent marker in either direction is visible. In no event shall pipeline identification signs be placed more than 500 feet apart, unless otherwise directed by the Director of Engineering for MBTA Railroad Operations.
- C. Submit details of signs (materials, size, methods of support, etc.) to the Director of Engineering for MBTA Railroad Operations for approval.

EXECUTION:

5.11 INSTALLATION:

- A. Install carrier pipes in accordance with approved Construction Drawings, requirements of this specification, and all applicable codes and ordinances.
- B. Install carrier pipes with sufficient slack so they are not in tension.

SECTION 6. CASING PIPE

GENERAL:

6.01 DESIGN CRITERIA

- A. Casing pipe and joints shall be of metal and of leak-proof construction.
- B. Casing pipe shall be designed for the earth and/or other pressures present, and for railroad live load. The dead load of earth shall be considered 120 pounds per cubic foot. Railroad Live load shall be Cooper E-80 with 50g added for impact.
- C. The inside diameter of the casing pipe shall be such as to allow the carrier pipe to be removed subsequently without disturbing the casing or the roadbed. For carrier pipe less than six (6) inches in diameter, the inside diameter of the casing pipe shall be at least two (2) inches greater than the largest outside diameter of the carrier pipe joints or couplings. For carrier pipe six (6) inches and over in diameter, the inside diameter of the carrier pipe shall be at least four (4) inches greater than the largest outside diameter of the carrier pipe joints or couplings.
- D. For flexible casing pipe, a minimum vertical deflection of 3 percent of its diameter, plus 1/2 inch, shall be provided so that no loads from the roadbed, track, traffic or casing pipe itself are transmitted to the carrier pipe. When insulators are used on the carrier pipe, the inside diameter of the flexible casing pipe shall be at least two (2) inches greater than the outside diameter of the carrier pipe for pipe less than eight (8) inches in diameter; at least 3-1/4 inches greater for pipe 8 to 16 inches in diameter, and at least 4-1/2 inches greater for pipe 18 inches and over in diameter. In no event shall the casing pipe diameter be greater than is necessary to permit the insertion of the carrier pipe.
- E. Casing pipe under railroad tracks and across MBTA Railroad Property shall extend the greater of the following distances, measured at right angles to centerline of track:
 - 1. Across the entire width of MBTA Railroad Property.
 - 2. Two (2) feet beyond ditch line.
 - 3. Three (3) feet beyond toe of slope.
 - 4. A minimum distance of 25 feet each side from centerline of outside track when casing is sealed at both ends.
 - 5. A minimum distance of 45 feet from centerline of outside track when casing is open at both ends.

F. If additional tracks are constructed in the future, the casing shall be extended at the expense of the Applicant.

G. Table of Live Loads

LIVE LOADS, INCLUDING IMPACT, FOR VARIOUS HEIGHTS OF COVER
FOR COOPER E- 80

COVER (FT)	LOAD (PSF)	COVER (FT)	LOAD (PSF)	COVER (FT)	LOAD (PSF)
2	3800	10	1100	20	300
5	2400	12	800	30	100
8	1600	15	600		

6.02 PROTECTION AT ENDS OF CASING

- A. Casings for carriers of flammable substances shall be sealed to the outside of the carrier pipe. Details of seals shall be shown on the Drawings.
- B. Casings for carriers of non-flammable substances shall have both ends of the casing blocked in such a way as to prevent the entrance of foreign material, but allowing leakage to pass in the event of a carrier break.
- C. Where ends of casing are at or above ground surface and above high water level, they may be left open, provided drainage is afforded in such a manner that leakage will be conducted away from railroad tracks and structures.

6.03 VENTS

- A. Sealed casings for flammable substances shall be properly vented. Vent pipes shall be of sufficient diameter, but in no case less than two (2) inches in diameter, and shall be attached near each end of the casing and project through the ground surface at right-of-way lines or not less than 45 feet (measured at right angles from centerline of nearest track).
- B. Vent pipes shall extend at least four (4) feet above the ground surface. Top of vent pipe shall have a down-turned elbow, properly screened, or a relief valve. Vents in locations subject to high water shall be extended above the maximum elevation of high water and shall be supported and protected in a manner approved by the Director of Engineering for MBTA Railroad Operations.
- C. Vent pipes shall be at least four (4) feet from the closest aerial electric

wires.

- D. When the pipeline is in a public highway, street-type vents shall be installed.

PRODUCTS:

6.04 STEEL PIPE

The minimum yield strength for steel pipe shall be 35,000psi. Smooth wall pipes with a nominal diameter greater than 70 inches require special approval by the Director of Engineering for MBTA Railroad Operations. See Plate V, "Table of Minimal Wall Thickness for Steel Casing Pipe."

6.05 CAST IRON PIPE

May be used for a casing, provided the method of installation is by open trench. Cast iron pipe shall conform to ASTM Specification A-142, Extra Heavy. The pipe shall be of the mechanical joint type or plain end type with compression type couplings.

6.06 CORRUGATED METAL PIPE AND CORRUGATED STRUCTURAL PLATE PIPE

May be used for casing only when emplaced by the open-cut method. Jacking or boring through railroad embankment is not permitted. Pipe shall be bituminous coated and shall conform to AREA Specifications Chapter 1, Part 4.

6.07 REINFORCED CONCRETE PIPE

Shall conform to ASTM Specification C 76, Class V, Wall C. It shall be used only in the open cut and jacking methods of installation. If concrete pipe is to be jacked into place, grout holes tapped for at least 1-1/2 inch pipe spaced at approximately 8 feet around the circumference and approximately 4 feet longitudinally shall be cast into the pipe at manufacture. Immediately upon completion of jacking operations, the installation shall be pressure grouted.

6.08 TUNNEL LINER PLATES

Shall be four flange and otherwise conform to American Railway Engineering Association Specifications Chapter 1, Part 4. In no event shall the liner plate thickness be less than 0.1046 inches. Tunnel liner plates are to be used only to maintain a tunneled opening until the carrier pipe is installed. After installation the annular space between the carrier and liner must be filled

with 1:6 cement grout or lined with 6 inches of concrete, reinforced with 6x6-6/6 wire mesh for tunnels up to 108 inches in diameter. Required thickness of lining for larger tunnels shall be determined by span and structural analysis. Manufacturer's Shop Detail Drawings and manufactures computations showing the ability of the tunnel liner plates to resist the jacking stresses shall be submitted to the Director of Engineering for MBTA Railroad Operations for approval.

EXECUTION:

6.09 DEPTH OF INSTALLATION:

- A. Casing pipe under railroad tracks and across MBTA Railroad Property shall be at least 6-1/2 feet from top of rail to top of casing at its closest point. Under secondary or industrial tracks this distance shall be at least 5-1/2 feet. On other portions of MBTA Railroad Property where casing is not directly beneath any track, the depth from ground surface or from bottom of ditches to top of casing shall be at least four (4) feet, unless otherwise specified herein.
- B. Pipelines laid longitudinally on MBTA Railroad Property 50 feet or less from centerline of track shall be buried not less than five (5) feet from ground surface to top of pipe. This applies to all pipelines carrying oil, gas, petroleum products, or other flammable or highly volatile substances under pressure, and all non-flammable substances which by their nature or presence in the judgment of the Director of Engineering for MBTA Railroad Operations may be hazardous to life or property. For pipelines carrying water, sewage and non-flammable substances, the distance from surface of ground to top of pipe shall not be less than four (4) feet.
- C. Pipelines located within the line of track live load influence (as shown on Plates II and III) are subject to railroad loading and require a casing or are to be of special design approved by the Director of Engineering for MBTA Railroad Operations. All longitudinal occupation locations must be approved by the Chief Engineering Officer.
- D. The minimum cover shall be at least three (3) feet when pipeline is laid more than 50 feet from center line of track.
- E. Pipelines installed under or adjacent to any overhead structure must be a minimum of 29 feet from the bottom of the structure to the top of the casing. Such installations must comply with the above requirements.

6.10 METHOD OF INSTALLATION

- A. The Owner or its Contractor shall submit to the Director of Engineering for MBTA Railroad Operations, data and information demonstrating that the Contractor or their subcontractors have had successful previous experience in jacking, or using the proposed method of installation, in similar situations.
- B. Before any work is begun within the limits of jacking, the Owner or its Contractor shall have assembled all tools, materials, and equipment which will be required. When the Owner or its Contractor has started the jacking operation, they shall proceed in a continuous operation without stopping. This will minimize the tendency of the material to freeze around the pipe.
- C. A jacking shield shall be used and jacked ahead of the casing pipe. The excavation within the jacking pipe should not advance beyond the head of the pipe shield. If the stability at the face needs to be maintained from raveling or running soil, suitable temporary bulkheads, struts, and bracing shall be required. After completion of the sleeve installation the annular space around it shall be completely grouted with cement grout under pressure.
- D. Casing pipe ends shall be beveled with a single V-groove toe field welding. Pipe joints shall be butt welded and shall be a full penetration on the outside circumference of the pipe. The single V-groove butt weld shall conform to the latest A.W.S. Welding Code. All joints of the casing pipe shall be butt welded, by a certified welder, prior to being subject to the jacking operation.

Alternate method: The casing pipe may be jacked without being butt welded through the use of a continuous 1/2"x12" interior collar plate. The collar plate shall be welded completely upon completion of the jacking operation. All welding shall conform to the latest A.W.S. Welding Code, and shall be performed by a certified welder.

6.11 CONSTRUCTION:

- A. The casing pipe shall be constructed so as to prevent leakage of any substance from the casing throughout its length, except where the ends are left open, or through vent pipes when the ends are sealed. The casing shall be installed so as to prevent the formation of a waterway under the railroad, shall have an even bearing throughout its length, and shall slope to one end (except for longitudinal occupancy).
- B. Casing pipes shall be installed by the following methods:

1. Jacking

- a. This method shall be in accordance with the most current edition of the American Railway Engineering Association Specifications, "Jacking Culvert Pipe Through Fills." This operation shall be conducted without hand mining ahead of the pipe and without the use of any type of boring, auguring, or drilling equipment.
- b. Bracing and backstops shall be designed and jacks of sufficient rating used so that the jacking will be continuous.

2. Drilling

This method employs the use of an oil field type rock roller bit or a plate bit made up of individual roger cutter units which are welded to the pipe casing being installed and which are turned as it is advanced. The pipe is turned for its entire length from the drilling machine to the ground being drilled. A high density slurry is injected through a small supply line to the head which acts as a cutter lubricant. This slurry is injected at the rear of the cutter units to prevent any jetting action ahead of the pipe. The drilling machine runs on a set of steel rails and is advanced (thus advancing the pipe) by a set of hydraulic jacks. The method is the same whether earth or rock is being drilled. Any other drilling methods shall be submitted to the Director of Engineering for MBTA Railroad Operations for approval.

3. Tunneling

- a. Tunneling operations shall be conducted as approved by the Railroad Company(s). Care shall be exercised in trimming the surface of the excavated section in order that the steel liner plates fit snugly against the undisturbed material. Excavation shall not be advanced ahead of the previously installed liner plates any more than is necessary for the installation of the succeeding liner plate. The vertical face of the excavation shall be supported as necessary to prevent sloughing. At any interruption of the tunneling operation, the heading shall be completely bulkheaded. Tunneling shall be conducted continuously, on a 24 hour basis until the tunnel liners extend at least one foot beyond the railroad line of influence.
- b. When tunneling, tight breasting must be maintained around the entire face. On any shutdowns (under or beyond railroad influence line, see Plate II), the entire

face shall be fully breasted and packed with hay.

- c. The tail void shall be filled with pea stone (or other approved material) simultaneously with each advancement of the shield.
- d. An ample supply of hay and/or sandbags must be kept at the site to fill any voids caused by the removal of large stones or other obstructions extending outside the shield.
- e. A uniform mixture of 1:6 cement grout shall be placed under pressure behind the liner plates, in addition to the previously placed pea stone. Grout holes, tapped for at least 1-1/2 inch pipe and spaced 3 feet around the tunnel liner, shall be placed in every other ring. Grouting shall start at the lowest dole and proceed upwards. A threaded plug shall be installed in each grout hole as the grouting is completed at that hole.
- f. Grouting shall be kept as close to the heading as possible, using grout stops behind the liner plates. If necessary, grouting shall proceed as directed by the Railroad Company(s), but in no event shall more than six lineal feet of tunnel be progressed beyond the grouting.

4. Tunneling Shields

- a. All pipes 70 inches and larger in diameter shall be emplaced with the use of a tunneling shield, unless otherwise approved by the Director of Engineering for MBTA Railroad Operations. Pipes of smaller diameter may also require a shield when, at the sole discretion of the Director of Engineering for MBTA Railroad Operations, soil, or other conditions indicate its need.
- b. The shield shall be of steel construction, designed to support railroad track loading as specified in Paragraph 6.01 B herein, in addition to other loadings it must sustain. The advancing face shall be provided with a hood, extending no less than 20 inches beyond the face and extending around no less than the upper 240 degrees of the total circumference. Installations made with liner plates shall be provided with a full 360 degree shield. It shall be of sufficient length to permit the installation of at least one complete ring of liner plates within the shield before it is advanced for the installation of the next ring of liner plates, It shall conform to and not exceed the outside dimensions of the pipe being emplaced by more than one inch at any point in the periphery.

- c. The shield must be adequately braced and provided with necessary appurtenances for completely bulkheading the face with horizontal breastboards, and arrange so that the excavation can be benched as may be necessary. Excavation shall not be advanced beyond the edge of the hood, unless otherwise approved by the Railroad Company(s).
- d. Manufacturer's Shop Detail Drawings and computations showing the ability of the tunnel liner plates to resist the jacking stresses shall be submitted to the Director of Engineering for MBTA Railroad Operations for approval.
- e. For jacking reinforced concrete pipe, the shield shall be fabricated as a special section of reinforced concrete pipe with the steel cutting edge, hood, breasting attachments, etc., cast into the pipe. The wall thickness and reinforcing shall be designed for the jacking stresses.
- f. Grout holes tapped for no less than 1-1/2 inch pipe, spaced at approximately 3 foot centers around the circumference of the shield (or the aforementioned special reinforced concrete section) and no more than 4 foot centers longitudinally shall be provided.
- g. Detail Drawings sufficient to determine the adequacy of the shield, accompanied with design calculations prepared by a Registered Professional Engineer, shall be submitted to the Director of Engineering for MBTA Railroad Operations for approval and no work shall proceed until such approval is obtained.

5. Boring

- a. This method consists of pushing the pipe into the fill with a boring auger rotating within the pipe to remove the spoil. When augers, or similar devices, are used for pipe emplacement, the front of the pipe shall be provided with mechanical arrangements or devices that will positively prevent the auger and cutting head from leading the pipe so that there will be no unsupported excavation ahead of the pipe. The auger and cutting head arrangement shall be removable from within the pipe in the event an obstruction is encountered. The over-cut by the cutting head shall not exceed the outside diameter of the pipe by more than one-half inch. The face of the cutting head shall be arranged to provide reasonable obstruction to the free flow of soft or poor material.
- b. Drawings and descriptions of the auger stop arrangement to be used shall be submitted to the Director of Engineering for MBTA Railroad Operations for approval,

and no work shall proceed until such approval is obtained and the arrangement is inspected in the field by the Railroad Company(s).

- c. The use of water or other Liquids to facilitate casing emplacement and/or spoil removal is prohibited.
 - d. Any method which employs simultaneous boring and jacking or drilling and jacking for pipes over 8 inches in diameter which does not have the above approved arrangement WILL NOT BE PERMITTED. For pipes 8 inches and less in diameter, augering or boring without this arrangement may be considered for use only as approved by the Director of Engineering for MBTA Railroad Operations.
- C. If an obstruction is encountered during the installation which stops the forward action of the pipe, and it becomes evident that it is impossible to advance the pipe, operations shall cease and the pipe shall be abandoned in place and filled completely with grout, in accordance with Section 4, Paragraph 4.10.
- D. Bored or jacked installations shall have a bored hole essentially the same as the outside diameter of the pipe plus the thickness of the protective coating. If voids should develop or if the bored hole diameter is greater than the outside diameter of the pipe (plus coating) by more than 1 inch, grouting or other methods approved by the Railroad Company(s) shall be employed to fill such voids.
- E. Pressure grouting or freezing of the soils before or during jacking, boring, or tunneling may be required at the direction of the Railroad Company(s) to stabilize the soils, control water, prevent loss of material and prevent settlement or displacement of the embankment and/or tracks. Grout shall be cement, chemical or other special injection material selected to accomplish the necessary stabilization.
- F. The materials to be used and the method of injection shall be prepared by a Registered Professional Engineer (Geotechnical), or by an experienced and qualified company specializing in this work and submitted for approval to the Railroad Company(s) before the start of work. Proof of experience and competency shall accompany the submission.
- G. When water is expected to be encountered, pumps of sufficient capacity shall be provided and maintained at the site, and continually attended on a 24-hour basis, until in the sole judgment of the Railroad Company(s), their operation can be safely halted.

When dewatering, close observation shall be maintained to detect any settlement or displacement of railroad embankment, tracks, and facilities.

- H. Proposed methods of dewatering must be submitted to the Railroad Company(s) for approval prior to implementation. The discharge from the dewatering operations in the vicinity of the railroad shall be carefully monitored. If in the opinion of the Railroad Company(s), there is an excessive loss of fine soil particles at any time during the dewatering process, the dewatering shall be halted immediately. The dewatering operation cannot resume until the unsatisfactory condition is remedied to the satisfaction of the Railroad Company(s).

PLATE I

PIPE CROSSING

INFORMATION TO BE SHOWN ON PLAN SECTION OF DRAWING

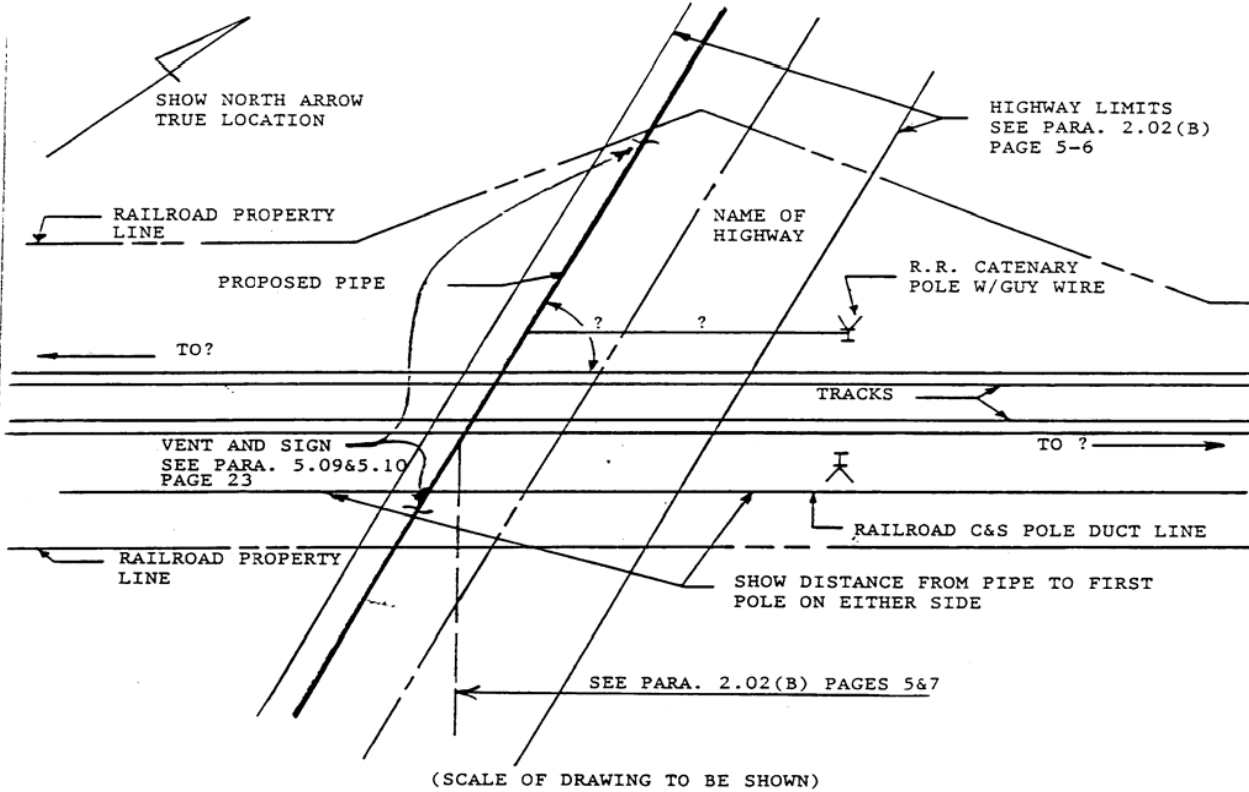

NOTE:

IF MANHOLES ARE PLACED ON MBTA RAILROAD PROPERTY, DETAILS OF SAME, WITH CLEARANCES TO THE CENTERLINE OF THE NEAREST TRACK ARE TO BE SHOWN ON THE DRAWINGS.

IF THE PROPOSED PIPE IS TO SERVE A NEW DEVELOPMENT, A MAP SHOWING THE AREA IN RELATION TO ESTABLISHED AREAS AND ROADS IS TO BE SENT WITH THE REQUEST.

THE PROPOSED PIPE IS NOT WHOLLY WITHIN HIGHWAY LIMITS, THE SAME INFORMATION IS REQUIRED AS SHOWN ON THIS PLATE.

PLATE II

PIPE CROSSING

INFORMATION TO BE SHOWN ON PROFILE SECTION OF DRAWING

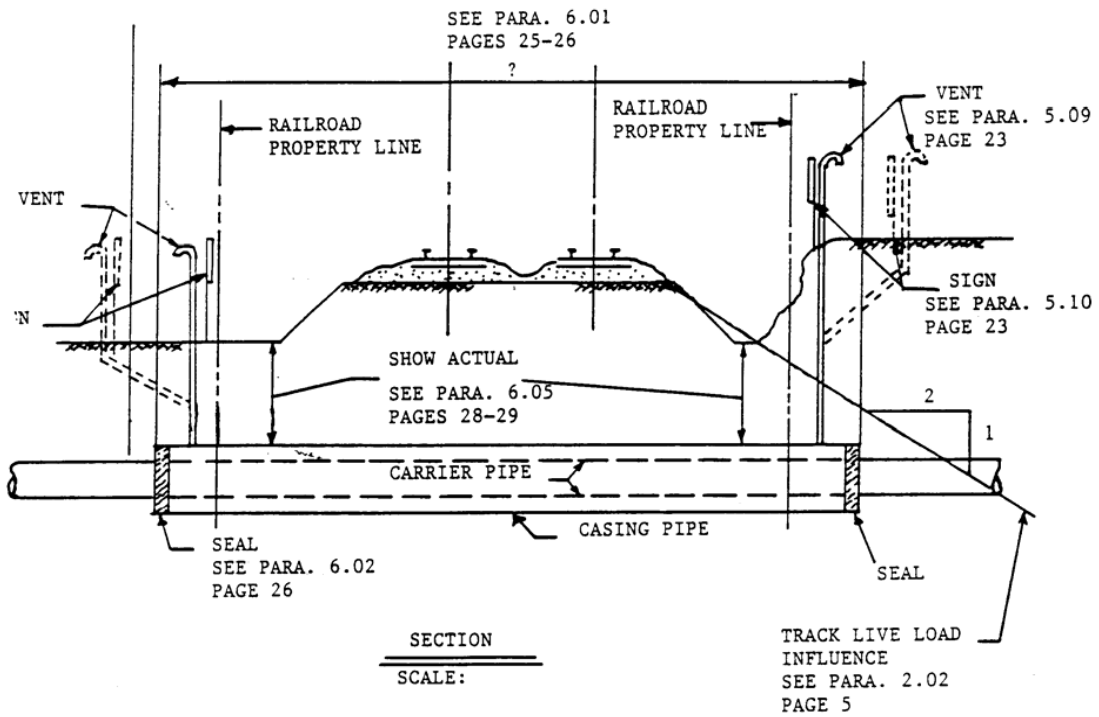
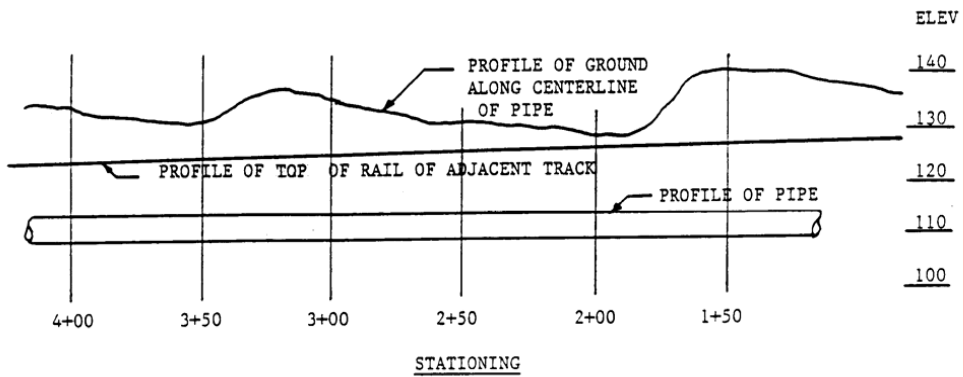
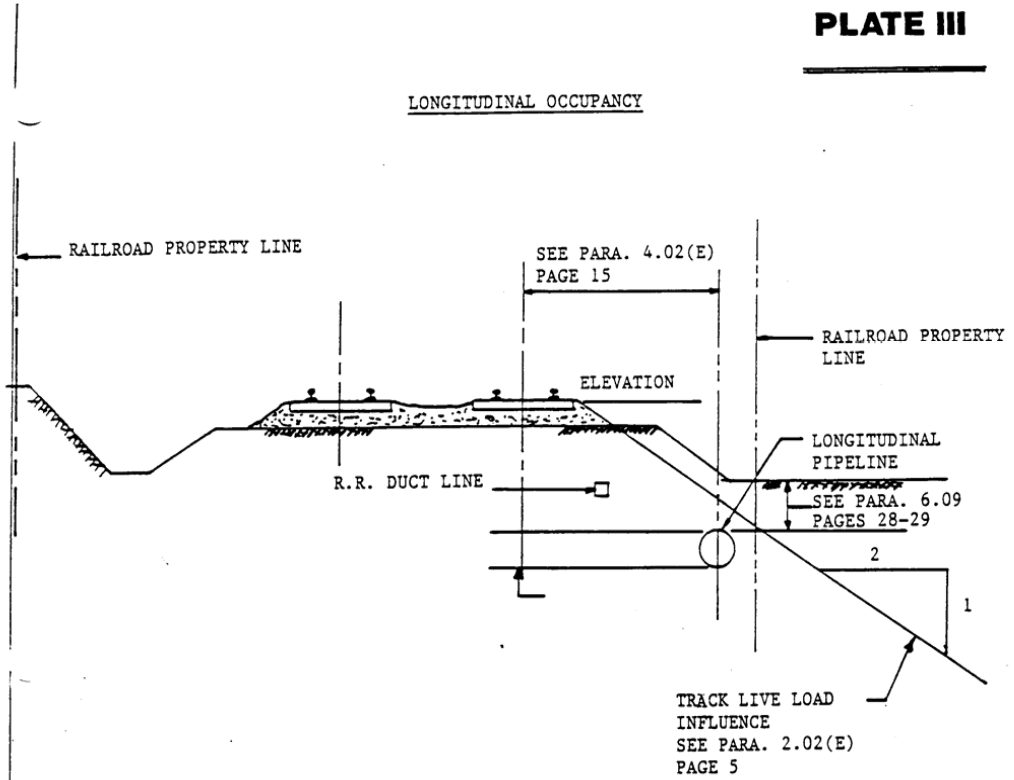

PLATE III

LONGITUDINAL OCCUPANCY



PROFILE - SEE PARA. 2.02
PAGES 5-7

SCALE - HOR:
VER:

PIPE CROSSING DATA SHEET

PLATE IV

In addition to plan and profile of crossing, Drawings submitted for the Railroad Company(s) approval shall contain the following information:

	<u>Pipe Data</u>	
	<u>Carrier Pipe</u>	<u>Casing Pipe</u>
Contents To Be Handled	_____	_____
Normal Operating Pressure	_____	_____
Normal Size of Pipe	_____	_____
O.S. Diameter	_____	_____
I.S. Diameter Wall	_____	_____
Thickness Weight	_____	_____
Per Foot Material	_____	_____
Process of Manufacture	_____	_____
Specification	_____	_____
Grade or Class	_____	_____
Test Pressure	_____	_____
Type of Joint	_____	_____
Type of Coating	_____	_____
Details of Cathodic Protection	_____	_____
Details of Seal or Protection at Ends of Casing:	_____	_____
Method of Installation	_____	_____
Character of Subsurface: Material At the Crossing Location	_____	_____
Approximate Ground Water Level	_____	_____
Source of Information on Sub-surface conditions (Test Pits, Borings or Other)	_____	_____

NOTE: Any soil investigation made on MBTA Railroad Property, or adjacent to tracks shall be carried on under the supervision of the Railroad Company(s).

PLATE V

TABLE OF MINIMUM WALL THICKNESS FOR STEEL CASING PIPE
(FOR INFORMATION ONLY)

PROTECTED WALL THICKNESS

PIPE SIZE (INCHES)	WALL THICKNESS (PROTECTED)
10	0.375
12	0.375
14	0.375
16	0.375
18	0.375
20	0.375
22	0.375
24	0.375
26	0.375
28	0.406
30	0.469
32	0.501
34	0.532
36	0.532
38	0.569
40	0.569
42	0.569
44	0.594
46	0.688
48	0.688
50	0.688
52	0.813
54	0.813
56	0.876
58	0.876
60	0.876
62	0.876
64	0.876
66	0.876
68	0.876
70	0.906

NOTE: - FOR UNPROTECTED PIPE 26" AND UNDER ADD 0.032" TO PROTECTED WALL THICKNESS. FOR UNPROTECTED PIPE 28" AND OVER, ADD 0.063" TO PROTECTED WALL THICKNESS.



**MASSACHUSETTS BAY
TRANSPORTATION
AUTHORITY**

RAILROAD OPERATIONS DIRECTORATE

V

**SPECIFICATIONS FOR WIRE CONDUIT AND CABLE
OCCUPATIONS**

SECTION 1. SCOPE

- 1.01 These specifications apply to the design of electric transmission wires and cables (power and communication) which are to be located over, under, across or upon property, facilities, and tracks owned by the MBTA.

SECTION 2. LICENSE TO ENTER MBTA RAILROAD PROPERTY

- 2.01 Individuals, corporations, or municipalities desiring wire or cable occupations must agree, upon approval of the construction details by the Director of Engineering for MBTA Railroad Operations, to execute an appropriate occupational agreement and pay any required fees and/or rentals outlined therein.

- 2.02 Application for an occupancy shall be submitted in writing to:

AGM for Real Estate and Asset Development
MBTA, 10 Park Plaza
Boston, Massachusetts 02116

See "Guidelines and Procedures for Construction on MBTA Railroad Property."

- 2.03 All applications shall be accompanied with six (6) copies of all Construction Drawings, specifications and computations concerning the proposed occupancy.

SECTION 3. APPROVAL OF DRAWINGS

- 3.01 Entry upon MBTA Railroad Property for the purpose of conducting surveys, field inspections, obtaining soil information, or any other purpose associated with the design and engineering of the proposed occupancy will be permitted only with a proper entry permit prepared by the MBTA Real Estate Department. The issuance of such a permit does not constitute authority to proceed with the actual construction. Construction cannot begin until the proper insurance certificate is received and a formal agreement is executed by the MBTA and permission is received by the Railroad Company(s).

- 3.02 Drawings shall be drawn to scale and show the following: (See attached plates I -VI)

- A. Plan view of crossing or occupation in relation to all Railroad Company(s) facilities. (See Plate 1)
- B. Location of wire or cane (in feet) from nearest railroad mile post, center line of a railroad bridge (giving bridge number), or center line of a passenger station. In all cases, the name of the County and City or

Town in which the proposed facilities are located must be shown.

- C. Profile of ground on center line of pole or tower line, showing clearances between top of rail and bottom of sag, as well as clearances from bottom wire or cable to top wire or cable of the MBTA's transmission, signal and communication lines and catenary. If none of these facilities are in existence at the point of crossing, the plan should so indicate. Actual under-clearances are to be shown. (See Plate V for the required clearances).
- D. Show all known property lines. If wires, cables or conduits are within public highway limits, such limits should be clearly indicated with dimensions from center line.
- E. The Drawing must be specific as to:
 - 1. Base diameter, height, class and bury of poles. Poles shall be set no closer than 13' 6" from face of pole to center line of nearest track. When necessary, however, each location will be analyzed by the MBTA to consider speed, traffic, access, etc.
 - 2. Number, size and material of power wires, as well as number of pairs in communication cables.
 - 3. Nominal voltage of line, type of current and frequency.
 - 4. Number, location, size and material of anchors and all guying for poles and arms.

NOTE: Double cross-arms are required on poles adjacent to track. Any tower designs must be accompanied by engineering computations and data.

SECTION 4. CONSTRUCTION REQUIREMENTS

4.01 Power and communication lines shall be constructed in accordance with "Safety Rules for the Installation and Maintenance of Electric Supply and Communication Lines, National Electrical Safety Code Handbook, Part 2" (current issue), with the following exceptions:

- A. Item 3 (c), page 2.
- B. Casing pipes to contain power or communication wires or cables having an outside diameter of over four (4) inches shall be constructed in accordance with the current issue of MBTA Railroad Operations "Pipeline Occupancy Specifications".

SECTION 5. LONGITUDINAL OCCUPATIONS

5.01 Wires and cables running longitudinally along railroad right-of-way shall be

constructed as close to MBTA property lines as possible in accordance with Plate III. For electrical power lines and cables with voltages of 34,500 or over and communication canes containing over 180 pairs, the following information must be submitted in addition to the detail of the pole top configuration as called for on Plate IV of these specifications:

- A. Voltage of circuit(s) or number of pairs. B. Phase of electrical circuit(s).
 - B. Number of electrical circuits.
 - C. Size (AWG or CM) and material of wires and cables.
- 5.02 Any facilities overhanging MBTA Railroad Property must have approval of the MBTA and appropriate rental charges will be applied.

SECTION 6. INDUCTIVE INTERFERENCE

- 6.01 On agreements covering longitudinal occupations, provisions shall be included that hold the Applicant responsible to provide appropriate remedies, at their own expense, to correct any inductive interference with MBTA facilities.

PLATE I

PLAN VIEW

INFORMATION TO BE SHOWN ON PLAN SECTION OF DRAWINGS
WHEN FACILITY IS A CROSSING

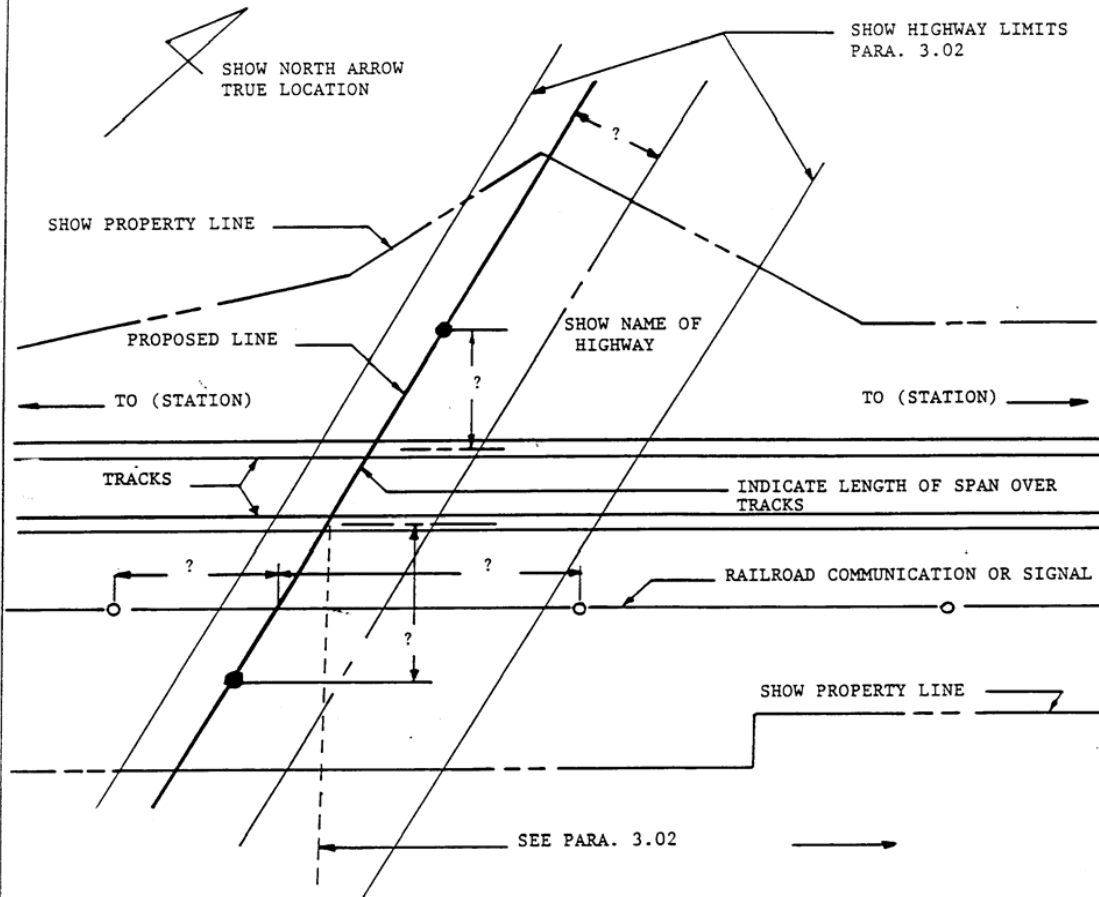

SCALE OF DRAWING TO BE SHOWN

NOTE:

IF THE PROPOSED LINE IS TO SERVE A NEW DEVELOPMENT, A MAP SHOWING THE AREA IN RELATION TO ESTABLISHED AREAS AND ROADS IS TO BE SENT WITH THE REQUEST.

IF THE PROPOSED LINE IS NOT WHOLLY (OR PARTIALLY) WITHIN HIGHWAY LIMITS, THE SAME INFORMATION IS REQUIRED AS SHOWN ON THIS PLATE.

PLATE II

PIPE CROSSING

INFORMATION TO BE SHOWN ON PROFILE SECTION OF DRAWING

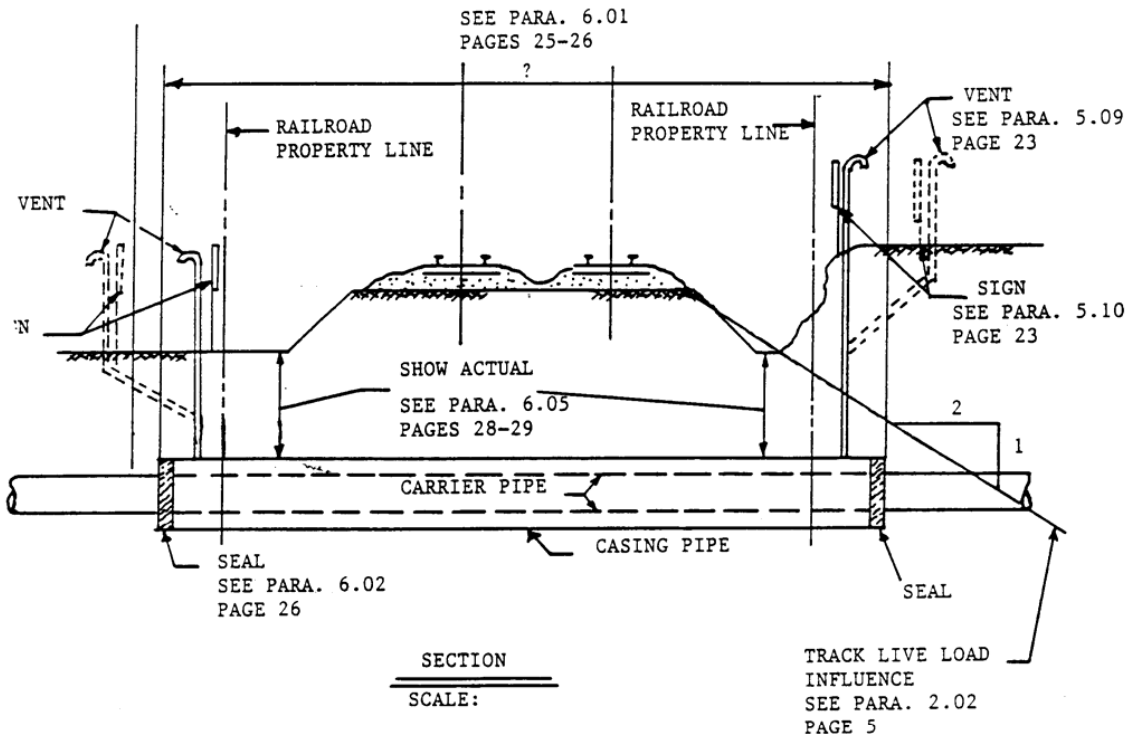
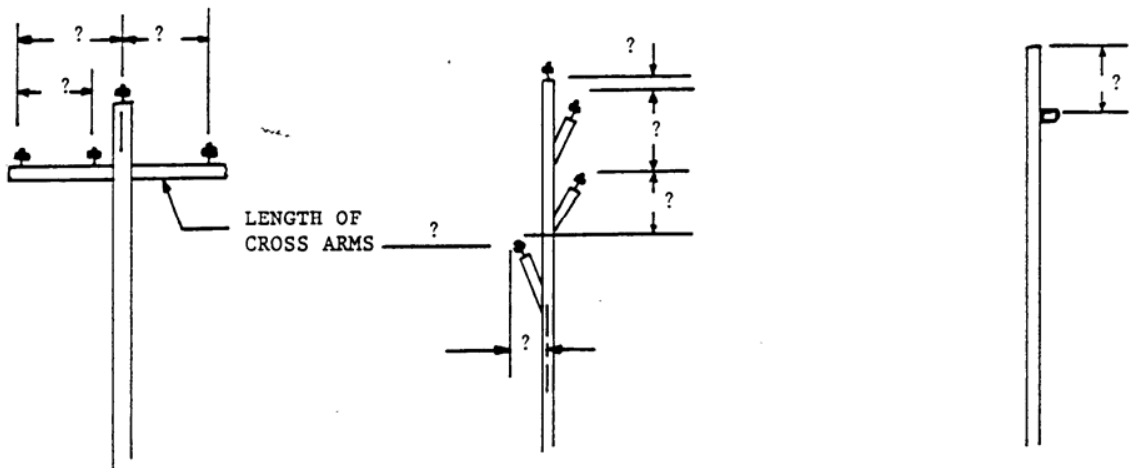
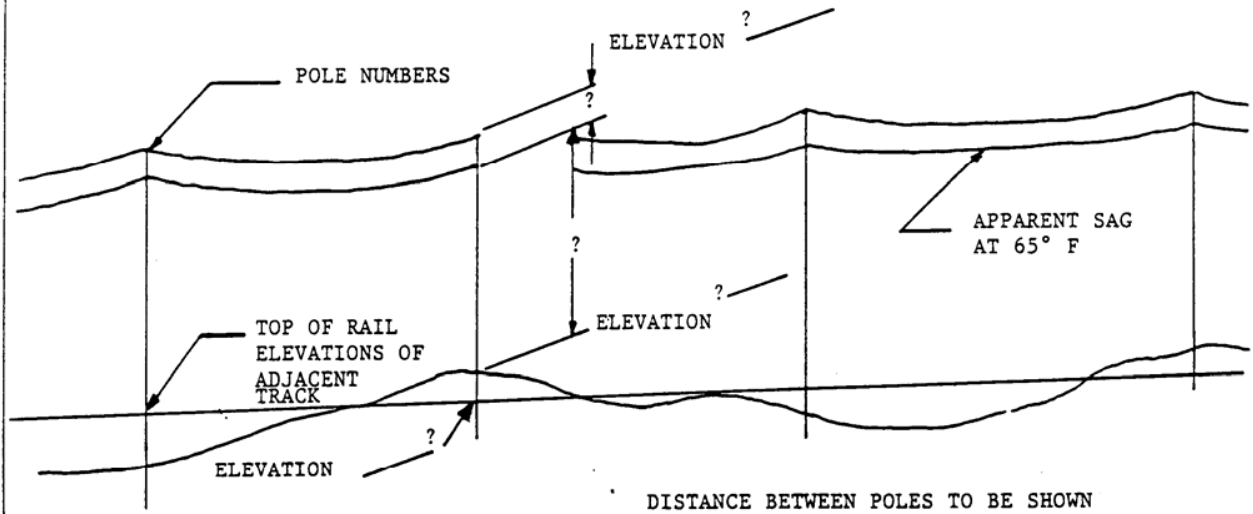

PLATE III

PROFILE VIEW

INFORMATION TO BE SHOWN ON PROFILE SECTION OF DRAWINGS
IN CASES OF LONGITUDINAL OCCUPATIONS



POLE TOP CONFIGURATION TO BE SHOWN SIMILAR TO SAMPLES ABOVE

NOTE: IF POWER LINE CROSSES ANY TRACK, THEN INFORMATION SHOWN ON PLATE II IS ALSO REQUIRED.

PLATE IV

STANDARD SIDE CLEARANCES - TANGENT TRACK

(FOR OBSTRUCTIONS OTHER THAN PASSENGER STATIONS)

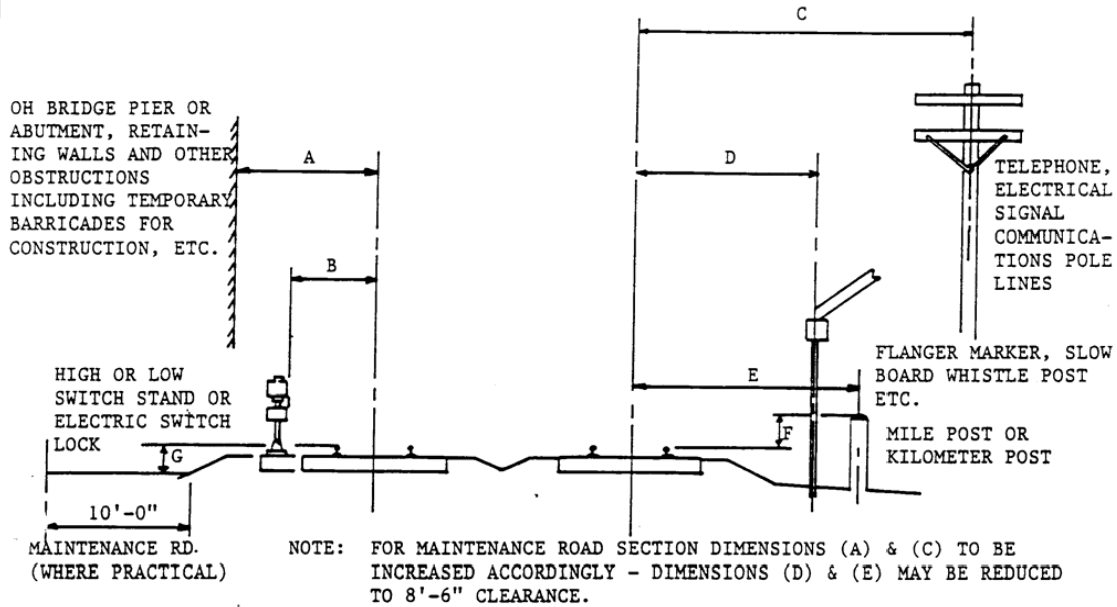

DIMENSION	DESCRIPTION	
A	GENERAL MINIMUM SIDE CLEARANCE	8'-6"
	OVERHEAD BRIDGE PIERS & ABUTMENT, RETAINING WALLS & OTHER EXISTING STRUCTURES	8'-6"
B	LOW SWITCH STANDS (3'-0" MAX HEIGHT)	6'-6"
	HIGH SWITCH STANDS (OVER 3'-0" HEIGHT)	9'-0"
	ELECTRIC SWITCH LOCKS	6'-6"
C	POLE LINES - TELEPHONE, ELECTRIC, SIGNAL COMMUNICATIONS (MIN)	13'-6"
D	CENTERLINE WHISTLE POSTS, FLANGER MARKERS, SLOW OR SPEED BOARDS AND OTHER WAYSIDE SIGNS	12'-0"
	AUTOMATIC HIGHWAY CROSSING PROTECTION (MIN)	8'-6"
	AUTOMATIC HIGHWAY CROSSING PROTECTION (DESIRED)	15'-0"
E	MILE POSTS - HORIZONTAL	13'-6"
F	MILE POSTS - VERTICAL	7'-0"
G	DEPRESSION OF MAINTENANCE ROAD	

PLATE V

<u>VOLTAGE</u>	<u>OVERHEAD CLEARANCE</u> (Top of Rail to <u>Bottom of Sag</u>)
0- 750	27'0"
750- 15,000	28'0"
15,000 - 50,000	30'0"
69,000	30'8"
115,000	32'2"
138,000	33'0"
345,000	39'10"
500,000	45'0"
745,000	53'2"
765,000	53'10"
Other than power lines	27'0"

At 120°F
Ambient
Temperature

(Calculation is 30'0" + 0.4" per 1,000 volts over 50,000 volts)

.....

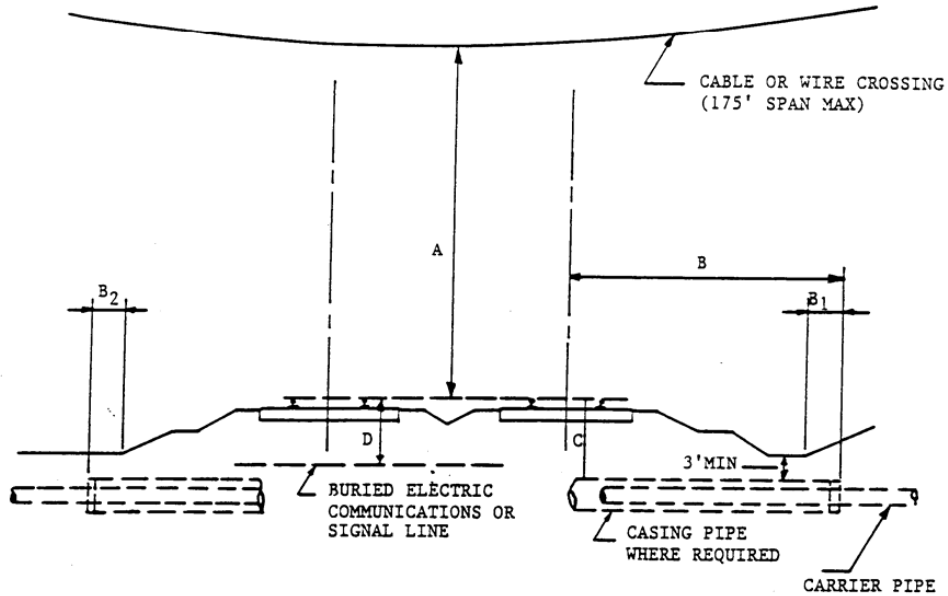

DIMENSION	DESCRIPTION		
A	POWER LINES 0 TO 750V	27'-0"	} At 120°F Ambient Temperature
	POWER LINES 750V TO 15,000V	28'-0"	
	POWER LINES 15 TO 50KV	30'-0"	
	OTHER THAN POWER LINES	27'-0"	
B	SEALED ENDED CASINGS	25'-0"	
	OPEN ENDED CASINGS	45'-0"	
B ₁	END CASING BEYOND DITCH	2'-0"	
B ₂	END CASING BEYOND SLOPE	3'-0"	
C	CASING PIPE	4'-6"	
	CARRIER PIPE WITHOUT CASING	6'-6"	
D	BURIED ELECTRIC LINES	6'-6"	
	RAILROAD SIGNAL LINES (220V)	2'-6"	
	COMMUNICATIONS LINES	3'-6"	

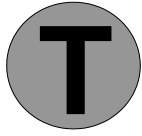

**MASSACHUSETTS BAY
TRANSPORTATION
AUTHORITY**

RAILROAD OPERATIONS DIRECTORATE

VI

**BRIDGE ERECTION, DEMOLITION AND HOISTING
OPERATIONS**

Submittals for bridge erection, demolition, or other hoisting operations shall be prepared and stamped by a Registered Professional Engineer and must include the following:

1. Plan view showing locations of crane or cranes, operating radii, with delivery or disposal locations shown.
2. Crane rating sheets showing cranes to be adequate for 150% of the lift. Crane and boom nomenclature is to be indicated.
3. Drawings and computations showing weight of picks.
4. Location plan showing obstructions, indicating that the proposed swing is possible.
5. Data sheet listing type and size of slings or other connecting equipment. Include copies of catalog cuts or information sheets of specialized equipment. The method of attachment must be detailed on the erection plan. All lifting components must be adequate for 150% of the lift.
6. A complete procedure indicating the order of lifts and any repositioning or re-hitching of the crane or cranes.
7. Drawings detailing temporary support of any components or intermediate stages.
8. A time schedule (by hour and day) of the various stages, as well as a schedule for the entire lifting procedure.



**MASSACHUSETTS BAY
TRANSPORTATION
AUTHORITY**

RAILROAD OPERATIONS DIRECTORATE

VII

TEMPORARY SHEETING AND SHORING

The following items are to be included in the design and construction procedures for all permanent and temporary facilities on, over, under, within or adjacent to MBTA Railroad Property:

1. Footings for all piers, columns, walls or other facilities shall be located and designed so that any temporary sheeting and shoring for support of adjacent track or tracks during construction will not be closer than toe of ballast slope. (See dimensions in the MBTA's Book of Standard Plans, #1000 and #1002 for tangent and curved track). Sheeting shall be required when excavation is inside of a line which extends horizontally from 5.5 feet off center line of adjacent track, then on a 2 (horizontal) to 1 (vertical) slope. This is known as the zone of influence.
2. Where physical condition of design impose insurmountable restrictions requiring the placing of sheeting closer than specified above, the matter must be submitted to the Director of Engineering for MBTA Railroad Operations for approval of any modifications.
3. When support of track or tracks is necessary during construction of above mentioned facilities, interlocking steel sheeting adequately braced and designed to carry E-80 live load plus 50% impact is required. Soldier piles and lagging will be permitted for supporting adjacent track or tracks only when required penetration of steel sheet piling cannot be obtained or when in the opinion of the Director of Engineering for MBTA Railroad Operations, or their authorized representative, steel sheet piling would be impracticable to place.
4. Exploratory trenches, three (3) feet deep and fifteen (15) inches wide in the form of an "H" with outside dimensions matching the outside of sheeting dimensions are to be hand dug, prior to placing and driving steel sheeting, in areas where railroad underground installations are known to exist. These trenches are for exploratory purposes only and are to be backfilled and compacted immediately. This work must be done in the presence of a railroad inspector.
5. Absolute use of track is required while driving sheeting adjacent to any track. Procedure for arranging the use of track shall be through the Railroad Company(s) representative on the project.
6. Cavities adjacent to sheet piling, created by driving of sheet piling, shall be filled with sand and any disturbed ballast must be restored and tamped immediately as required by the Railroad Company(s).
7. Sheet piling shall be cut off at top of tie during construction. After construction and backfilling has been completed, the piling within twelve (12) feet from centerline of track shall be cut off 24" below bottom of tie or 24" below finished grade, whichever is greater. Sheeting, used as a form on a permanent

structure, shall be cut as directed by the Railroad Company(s).

8. The excavation adjacent to the track shall be covered and protected by handrails and barricades, warning lights shall be provided by the Contractor as directed by the Railroad Company(s).
9. Graded backfill material shall be compacted at near optimum moisture content, in layers not exceeding 6 inches in compacted thickness, by pneumatic tampers, vibrator compactors, or other approved means to the base of the railroad subgrade. Material in the vicinity of sheet pile shall be compacted to not less than 95 percent of AASHTO T 99, Method C. The Contractor shall be required to supply, to the job site, ballast stone as prescribed herein to be installed by the Railroad Company(s).
10. The Contractor is to advise the Railroad Company(s) of the time schedule of each operation and obtain approval of the Railroad Company(s) for all work to be performed adjacent to MBTA tracks so that it may be properly supervised by railroad personnel.
11. All Drawings for temporary sheeting and shoring shall be prepared and stamped by a Registered Professional Engineer and shall be accompanied by complete design computations when submitted for approval.
12. Particular care shall be taken to avoid erosion or filling of the Railroad Company(s) drainage facilities. Erosion and sediment control in the vicinity of the railroad shall be as approved by the Director of Engineering for MBTA Railroad Operations. Correction of disrupted Railroad Company(s) drainage facilities shall be at the Contractor's sole expense.

MBTA REQUIREMENTS FOR GEOTECHNICAL MONITORING

THE FOLLOWING SPECIFICATIONS ARE REQUIRED FOR ALL PILE DRIVING/EXCAVATING OPERATIONS:

1. Pile driving shall be on a continuous basis for each pile driven. Once a pile is started, it shall be driven or cut off at an elevation not to exceed the plane across the top of the rails of any track within 8'-6" plus 2" for each degree of curvature from centerline of track to the closest edge of the edge or excavation.
2. The monitoring points shall be set up one week before the pile driving or excavation operations begin. The MBTA and the Railroad Company(s) shall be notified. Elevation readings to establish the initial baseline reading shall begin two days prior to the start of driving. Readings shall be for a minimum of two weeks after the completion of the driving or backfilling of the excavation, whichever is longer. Initial readings immediately after any surfacing operations shall serve as new baseline figures. All future elevation readings shall be compared to the adjusted baseline. If the track deviates to a condition that is unacceptable to the MBTA or Railroad Company(s), corrections shall be made at the Contractor's expense.
3. Elevation readings shall be taken from the top of each rail of each track within the "zone of influence" the excavation. See Section 1, Page 1 of this specification.
4. Elevation readings will be taken once per eight hour shift. The readings shall be faxed to the MBTA Railroad Company(s) on a daily basis and all information is to be presented in legible print. During excavation within the sheet pile protected area, the top of rail elevations shall be checked every hour. Additional readings may be required by the MBTA or Railroad Company(s).
5. Stations shall be spaced at 15-1/2 foot intervals. The number of distractions required will be determined by the length of the excavation parallel to the tracks. There will be four additional stations on each end of the pile driving/excavation operation along the track. Extra stations may be required by the MBTA or Railroad Company.
6. Elevation readings must show the date, time, weather conditions and temperature. Each reading must also provide the following information: track number, compass direction, station number, base elevation (with date), static elevation, change in elevation (recorded in hundredths and in inches), dynamic reading and total deflection in inches. See sample sheet attached.
7. Station "0" will be located at the centerline of the project with Stations 1, 2, 3, etc., being to the right and Stations -1, -2, -3, etc., being to the left when

standing on the near track and looking at the work. In multiple track areas the stations as determined herein are to be carried across each track located within any part of the zone of influence. See Plate I.

8. At each monitoring station a dynamic load measurement shall be taken. The dynamic load measurement device shall consist of a wooden stake placed firmly in the ballast and in initially in contact with the bottom of the rail. The loaded measurement is the resultant gap between the bottom of the rail and the top of the stake caused by the deflection of the rail under the load of a passing train. Based on field observations of the excavation, and at the option of the MBTA or railroad company(s), this requirement may be reduced.
9. Elevation readings taken from the top of rail for static measurement and the dynamic reading shall be combined and the sum compared to the adjusted baseline. This reading will demonstrate the difference in elevation caused by the excavation.
10. The MBTA requires that the track be maintained at all times within established criteria for the specific track classification. At the completion of the project the requirement for tamping and realigning the tracks, caused by the settlement from the construction activity, remains with the Contractor for the duration as specified by the MBTA in their initial review of the Construction Drawings. This tamping and track realignment will be performed by the MBTA or railroad company(s) at the sole expense of the Contractor.

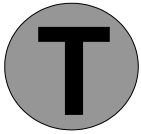

**MASSACHUSETTS BAY
TRANSPORTATION
AUTHORITY**

RAILROAD OPERATIONS DIRECTORATE

VIII

BLASTING SPECIFICATIONS

Blasting on, over, under, within or adjacent to MBTA Railroad Property will be permitted only in special cases where it is demonstrated to the Director of Engineering for MBTA Railroad Operations that there is no practicable alternative to perform the work.

In such cases when blasting is permitted, the Contractor must submit a detailed blasting program to the MBTA and Railroad Company(s) for approval prior to the commencement of any work. The blasting program must contain the following information:

- a. Site plan with location of nearest MBTA structure.
- b. Plan of each blast showing hole spacing and delay pattern.
- c. Diameter and depth of each hole.
- c. Amount of explosives per hole.
- d. Total pounds of explosives per day.
- e. Total amount of explosives per blast.
- f. Type of non-electric delays to be used.
- h. Amount of stemming in each hole.
- g. Type of explosive to be used.
- h. Soil and rock profile in blast zone.
- i. Scaled distance to the nearest MBTA facility.
- j. Type and location of seismograph to be used.
- m. Size of blasting mats to be used.
- k. Safety precautions to be followed.

The following general requirements are to be adhered to:

- a. Obtain the services of a qualified vibration and blasting consultant to monitor the blasting.
- b. Use a non-electric detonation system whenever possible. If electric caps are used, a check must be made for stray currents, induced current and radio frequency energy to insure that this hazardous extraneous electricity is at an acceptable safe level.
- c. Provide an open face for maximum relief of burden.
- d. Limit the maximum peak particle velocity to 1 inch per second. Depending on existing conditions, this may be modified to 2 inches per second.
- e. Maintain an initial scale distance of 60 ft. per 1-1/2 lbs. After initial blasting, scale distance may be modified to a minimum of 50 ft. per 1-1/2 lbs., if conditions permit.

Scale distance -- Distance from blast to structure (in feet)

Weight of explosives per delay (in pounds)

The Contractor shall provide for a pre-blast and post blast survey, including photographs. An inspection of all nearby MBTA facilities shall be made to determine any changes that may occur due to blasting operations.

The Contractor shall coordinate all blasting with the MBTA and Railroad Company(s) in advance to determine when the charges may be set. The Contractor is advised that the MBTA and Railroad Company(s) use two way radios for train control. The radios operate in the 160 MHz area. These radios cannot be turned off at any time.

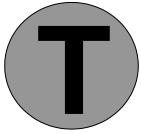

**MASSACHUSETTS BAY
TRANSPORTATION
AUTHORITY**

RAILROAD OPERATIONS DIRECTORATE

IX

**TEMPORARY PROTECTION SHIELDS FOR DEMOLITION AND
CONSTRUCTION**

The Railroad Company(s) will determine when and where protection shields are required. The designated construction of temporary protection shields must adhere to the following specifications:

1. The construction of temporary protection shields shall be designed to prevent any dust, debris, concrete, formwork, paint, or tools from falling on MBTA Railroad Property below.
2. The temporary protection shields shall be erected prior to the start of work. The Railroad Company(s) will determine whether or not sufficient protection has been provided to perform the work over any particular area.
3. The temporary protection shields shall remain in place until all work over the railroad has been completed and shall be removed only when ordered by the Railroad Company(s).
4. To minimize the inconvenience to the users of any properties below and adjacent to the project, the Contractor shall be required to complete the actual erection and removal of the temporary shields within time limits acceptable to the Railroad Company(s).
5. The erected temporary protection shields shall not infringe on any existing minimum vertical clearance.
6. The Contractor shall be required to obtain the approval of the Railroad Company(s) before commencing any work beneath the shield. In certain areas, depending on the nature of the work, the Railroad Company(s) may require a specific method of protection.
7. The horizontal shield shall be designed to carry a live load of 100 pounds per square foot and a single concentrated load of 2,000 pounds located to produce maximum stress. The vertical shield shall be designed to carry a wide load of 30 pounds per square foot.
8. Prior to the start of construction, the Contractor shall be required to submit the details of the temporary protection shield to the Railroad Company(s), who will review and approve the details only as to the methods of erection and as to whether or not the proposed installation will provide the level of protection required at the various locations. It is the Contractor's responsibility to design these protections so that they are in conformance with all existing laws, regulations and specifications that govern this type of work. Shield plans must include a material list and shall be designed by a Registered Professional Engineer. The Drawings and calculations must bear their seal when they are submitted to the Railroad Company(s).
9. If during the actual construction, the Railroad Company(s) deems that the shield is not providing the desired level of protection or that the Contractor has failed to properly maintain the shield, all work at the

affected location shall cease until corrective measures acceptable to the Railroad Company(s) are instituted.

10. All temporary shields shall be constructed using new material.

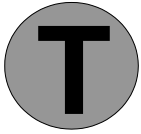

**MASSACHUSETTS BAY
TRANSPORTATION
AUTHORITY**

RAILROAD OPERATIONS DIRECTORATE

X

INDUSTRIAL SIDE TRACK SPECIFICATIONS

SECTION 1. GENERAL

- 1.01 All railroad track construction shall be performed under competent supervision of personnel experienced in railroad construction and shall conform to the standards of the MBTA. The MBTA and Railroad Company(s) will inspect and approve all side tracks prior to being put in service. This specification shall be used for side tracks directly on or within 15 feet of the MBTA property line. Any construction outside of the MBTA property line shall be in compliance with the standards of the serving freight railroad.

SECTION 2. MATERIALS

2.01 MATERIAL

Rails, ties, switches, frogs, etc. shall conform to the standards of the MBTA for various types of turnouts and track installations thereby insuring replacement availability.

2.02 RAIL

The rails shall be 100# ASCE Section or of a heavier rail section in common use, new or relay. Relay rails shall not have more than 1/4" top wear measured vertically along center line of rail and not more than 3/8" side wear measured horizontally 3/4" below the normal top of rail. Rails shall be free from kinks, excessive rust and excessive head flow. Rails having line or surface bends that cannot be spiked will be rejected. Rail shall be free of internal defects. Rail used on the limits of MBTA Railroad Property shall be equal in weight and in section to the attached main line.

2.03 CROSS TIES

Cross ties shall conform to MBTA specifications, minimum size shall be 7" x 8" x 8'6" and shall be treated with creosote in accordance with MBTA specifications. Relay ties may be approved after inspection by the MBTA and Railroad Company(s) prior to installation.

2.04 SWITCH TIMBER

Switch timber shall be new hardwood and conform to MBTA specifications 7" x 9" and of lengths required by MBTA standard turnout bill of materials. All timber shall be creosote treated as specified for cross ties. Relay timber as above.

Tie plates shall be new or relay at least 7-1/2" x 10-3/4", 1/2" thick,

double shoulder and should be canted. Tie plates must conform to MBTA specifications. Damaged plates or plates showing more than 25% reduction in section due to corrosion or wear will be rejected.

2.06 JOINT BARS

Joint bars shall be new or relay, 100% toeless, 24" long or equal and conform to MBTA specifications. Relay bars must be free from appreciable wear. Joint bars shall have a minimum of four holes and the holes are to fit the punching's of the rail. Holes to have a clearance of 1/16". Joint bars that cannot be drawn up to give a tight fit will be rejected. No fewer than 4 bolts per joint will be allowed.

2.07 BOLTS, NUTS AND WASHERS

Bolts and nuts shall be new and of a size to fit the rail punching's. They shall conform to AREA specifications for low carbon steel track bolts and nuts. Washers shall be new spring type of appropriate size and shall conform to MBTA specifications.

2.08 TRACK SPIKES

Track spikes shall be 6" long, 5/8" square with an oval head and conform to MBTA specifications for soft steel track spikes. Tangent track shall have at least 2 rail holding spikes per tie plate and all curves over 3" shall have 3 spikes per tie plate.

2.09 BALLAST

Ballast shall conform to MBTA Material Specification 9248.

2.10 BUMPING POSTS

Bumping posts shall be Hayes type, Durable "D" or equal, unless otherwise specified, and will conform to MBTA Material Specification 9206.

2.11 DERAIL

Type and quality of derail shall be specified for each individual side track requirement. Derail shall be connected into the railroad signal system, which will be performed by the Railroad Company(s) at the Owner's expense. Two pairs of insulated joints shall be installed by the Contractor at a location to be determined by the MBTA. Side tracks with a descending grade toward the main track shall require a split switch type derail.

SECTION 3. INSTALLATION

- 3.01 The track shall be properly installed with a standard gauge of 4'8-1/2" except on sharp curves. In cases of sharp curves, gauge will be specified by the MBTA or the Railroad Company(s).
- 3.02 Ballast shall be installed on top of subgrade for a depth of at least 6" below the bottom of tie and brought up to the top of the tie at the center and slope off to 1" below top of tie at the ends. It shall then extend 1' beyond the end of the tie at that height, at which point it shall slope off at a rate of 2:1 to the sub- ballast.
- 3.03 Cross ties shall be placed not more than 24" on center on tangent track and 19 ½ " on center on curved track. When relay rails are used the unworn side shall be placed on the gauge side. Tie plates shall be installed on each cross tie. The center of the joint shall be installed so as to be suspended by two ties.
- 3.04 It shall be the responsibility of the builder of that portion of track designated as "property line to end" to connect to that portion of track designated as "clearance to property line" and provide the necessary joints or compromise joints with bolts as the weights of rail would dictate.

SECTION 4. BONDING

- 4.01 Where track bonding is necessary, it will be performed by the Railroad Company(s) in accordance with MBTA standards.

SECTION 5. APPROVAL

- 5.01 Plans for track installation must be approved by the MBTA and Railroad Company(s) before the design of the facility to receive rail service is finalized.

SECTION 6. CURVATURE OF TRACK

- 6.01 The recommended curvature shall be 8⁰ or less. The maximum allowable degree of curve is not to exceed 12⁰ 30', unless approved by the Director of Engineering for MBTA Railroad Operations.

SECTION 7. GRADE OF TRACK

- 7.01 The maximum allowable grade for all tracks shall not exceed 1.5% descending towards mainline or 3% descending from mainline using 100 foot vertical curves.

SECTION 8. ELEVATION

8.01 Super elevation shall not exceed 1 inch.

SECTION 9. SUBGRADE

9.01 Subgrade shall be prepared to a grade 18" - 20" below the proposed top of rail and shall be of a material that is compacted to 95% and provides for adequate drainage.

SECTION 10. ACCEPTANCE

10.01 Before track is placed into service to receive cars, it shall be inspected and approved by a qualified track inspector from the MBTA, the Railroad Company, and the freight carrier.

10.02 No exceptions to these specifications are authorized without the written approval of the Director of Engineering for MBTA Railroad Operations.



**MASSACHUSETTS BAY
TRANSPORTATION
AUTHORITY**

RAILROAD OPERATIONS DIRECTORATE

XI

RIGHT OF WAY FENCING SPECIFICATIONS

SECTION 1. GENERAL

1.01 DESCRIPTION

This section specifies the furnishing and installing of new Type I galvanized steel or Type II aluminum coated steel chain link fence. Right of way fence shall be 6', 8' or 10' as required by site specific conditions.

1.02 SUBMITTALS

Shop Drawings

1. Include cross sectional dimension of posts, braces, rails, fittings, accessories and gate frames, design of gates, and details of gate hardware.
2. Include a layout drawing showing the spacing of posts and location of all gates, abrupt changes in grade, and all corner, gate, anchor, end and pull posts.

SECTION 2. PRODUCTS

2.01 MATERIALS

A. General

1. Steel pipe dimensions and weights: ASTM A-53, Schedule 40 (except the hydrostatic testing requirement is waived). Dimensions specified are outside diameter (O.D.).
2. Provide post with accepted semi-steel or pressed steel tops, so designed as to fit securely over post and carry top rail or spring tension wire; the base of post top fitting shall fit over the outside of post and shall exclude moisture from post. All fittings and accessories shall be hot dipped galvanized in accordance with ASTM A-53.

B. Line Post: For all post heights, unless otherwise noted, Schedule 40, 2.375" O.D. pipe weighing 3.65 lbs./ft. ASTM A-53 with a 2 oz. hot dipped galvanized coating shall be used.

C. Gate post: Furnish post to support single gate leaf, or one leaf of a double gate installation, for the following gate widths:

<u>Leaf Width</u>	<u>Gate Post</u>	<u>Sch. 40</u>
up to 6'	2.875" O.D.	5.79 lb./ft.
6' to 12'	4.000" O.D.	9.11 lb./ft.
12' to 18'	6.625" O.D.	18.97 lb./ft.
18' to 32'	8.625" O.D.	28.55 lb./ft.

D. End, Corner and Intermediate Posts

For all post heights, unless otherwise noted, Schedule 40, 2.875" O.D. pipe weighing 5.79 lbs./ft. ASTM A-53 with a 2 oz. hot dipped galvanized coating shall be used.

E. Top rail and Spring Tension Wire

1. Top Rail

- a. Schedule 40, 1.66" O.D, pipe weighing 2.27 lbs./ft. ASTM A-53 with a 2 oz. hot dipped galvanized coating.
- b. Couplings and expansion sleeves: Outside sleeve type, minimum six inches long.

2. Spring tension wire: shall be marcelled (spiraled or crimped) #7 gauge (.177 inches) plus or minus 0.005 inches in diameter. ASTM A-824. 1.2 oz. zinc per sq. ft.

F. Braces and Tension Rods

1. Compression braces: Same type and size as top rail.
2. Tension rods: 3/8" round rods with drop forged turnbuckles or other approved type of adjustment.

G. Fence Fabric

1. Type I galvanized steel ASTM A-392 Class 2 coating 2 oz.
 - a. Typical-2" diamond mesh 6 gauge (192") 2 oz.
 - b. Hot dipped galvanizing after weaving.
2. Type II aluminum coated steel ASTM A-491 size 2. 3/8" mesh.
3. Selvages: All types
 - a. Fabric shall be knuckled at both selvages.
 - b. Fabric over 60 inches high: knuckled at one selvaage and twisted and barbed at the other.

H. Fabric Bands, Brace Bands and Stretcher Bars

1. Fabric Bands: 12 gauge pressed steel 7/8 inch wide.
2. Brace Bands: 11 gauge pressed steel 1 inch wide.
3. Stretcher Bars: 3/16" x 3/4" galvanized steel.

- I. Tie wire and miscellaneous Items
 - 1. Tie Wire: Galvanized steel 6 gauge (.192") for post and rails.
 - 2. Hog rings: Galvanized steel 6 gauge (.192") for spring tension wire.
 - 3. Rail and Truss Cups: Galvanized semi-steel or pressed steel.

- J. Barbed Wire and Extension Arms
 - 1. Barbed Wire; ASTM A121, 12-1/2 gauge, 4-point round barbs, Class 3 coating.
 - 2. Extension Arms: Projecting at an angle of approximately 45 degrees, fitted with clips or other means of attaching three strands of barbed wire, the top outside wire approximately 12 inches from the fence line and the other wires spaced uniformly between the top outside wire and the fence fabric.

- K. Gates
 - 1. General: Furnish gates complete with necessary hinges, latches, and drop bar locking devices; corners shall be welded or fastened and reinforced with suitable fittings.
 - 2. All gates fabricated from 1.90" O.D. Schedule 40 pipe weighing 2.72 lbs./ft. with a 2 oz. hot dipped galvanized coating.

- L. Concrete: Class 2500 psi concrete consisting of aggregate passing the No. 8 sieve.

SECTION 3. EXECUTION

3.01 INSTALLATION

- A. Place terminal post at each end, corner, gate post, pull post (minimum 500'), or any change in grade or direction greater than 30 degrees.

- B. Line posts shall be spaced on a maximum of 10 foot centers. In determining the post spacing, measure parallel to slope of finished grade. All posts to be set plumb and in line. Post spacing on radius as follows:

200'- 500' radius 8' O.C.
 100' - 200' radius 6' O.C.
 less than 100' radius 5' O.C.

- C. When fencing is installed on the top of concrete structures, use galvanized sleeve and grout posts or install with suitable galvanized flange casing and galvanized anchor bolts. Set all other posts permanently in concrete.
- D. Excavate post hole footings at least 12" in diameter for line post and 16" for terminal and gate posts up to 4" O.D. Larger gate posts require 18" diameter footings. All footings excavated to a depth of 42" with a minimum post embedment of 36". Crown top of concrete to shed water and allow curing for not less than 72 hours before proceeding with further work on the post.
- E. Brace end, corner pull, and gate posts to the nearest line post with diagonal or horizontal brace rails used as compression chambers, and with truss rods with turnbuckles used as tension members. Brace line posts horizontally and truss in both directions as required, at approved intervals.
- F. Install fabric on post side which best secures MBTA's Railroad Property. Pull fabric taut and tie to all line posts, rails, braces and spring tension wire spacing all ties at 12" intervals. Use hook shaped steel ties confined to the diameter of the pipe to which it is attached, clasping pipe and fabric firmly with both ends twisted at least 2 turns.
- G. Barbed wire and tension wire must be taut and properly secured with brace bands at each terminal and gate post.
- H. Electric Ground: Where a power line carrying more than 600 volts passes over fence, install ground rod at the nearest point directly below each point of crossing. Ground all substation fences and gates and perform other electrical grounding as indicated.

3.02 TOUCH-UP AND REPAIR WORK

Remove and replace fencing which is improperly located or is not true to line, grade and plumb within tolerances as indicated.



**MASSACHUSETTS BAY
TRANSPORTATION AUTHORITY**

RAILROAD OPERATIONS DIRECTORATE

XII

TEST BORINGS SPECIFICATIONS

SECTION 1. GENERAL

All borings on MBTA Railroad Property are to be performed according to the following requirements:

- 1.01 Work on MBTA Railroad Property must be performed with a Railroad Company(s) inspector and/or flagman present.
- 1.02 Where access can only be gained by crossing the tracks, a temporary crossing must be used. This crossing shall adhere to the following:
 - A. The location and material must be approved in advance by the Chief Engineering Officer or Railroad Company(s).
 - B. The crossing will be constructed by Railroad Company(s) forces at the Contractor's expense.
 - C. The crossing must be protected at all times when not in use. Access shall be prohibited through the use of right-of-way gates which will be constructed by Railroad Company(s) forces at the Contractor's expense.
 - D. No crossing of the track shall be made without a railroad flagman and/or inspector present.
 - E. The crossing of tracks shall be kept to a minimum.
- 1.03 Boring locations, including positioning of the boring rig, shall be kept at least 8'-6" from the center line of track.
- 1.04 All borings must be cased to insure adequate return (of mud and water) and to avoid undermining of the track.
- 1.05 All holes shall be backfilled with cement grout to fill the voids and protect against an artesian condition.
- 1.06 The location of all utilities owned or private, shall be located and suitably marked by the Railroad Company(s) and/or the private owner at the Contractor's expense to avoid damage to the utility and/or track structure.
- 1.07 Prior to entry upon the MBTA Railroad Property, all necessary contracts, insurance policies and financial obligations shall be provided in a form acceptable to the Railroad Company(s).
- 1.08 Work within the operating right-of-way that has potential to foul the tracks, shall be restricted to periods of non-peak passenger operations.

- 1.09 While performing the work, full cooperation with the inspector and flagman is essential. The work will be terminated immediately if the safety of all traffic and personnel is jeopardized in any way.

SECTION 2. TESTING

- 2.01 Soil borings shall be in accordance with the current issue of the American Railway Engineering Association Specifications, Chapter 1, Part 1, "Specifications for Test Borings". Soils shall be investigated by the split-spoon and/or thin-walled tube method and rock shall be investigated by the Coring method specified therein.
- 2.02 Soil boring logs shall clearly indicate all of the following:
1. Boring number as shown on boring location plan.
 2. Elevation of ground at boring.
 3. Description or soil classification of soils and rock encountered.
 4. Elevations or depth from surface for each change in strata.
 5. Identification of where samples were taken and percentage of recovery.
 6. Location of ground water at time of sampling and, if available, subsequent readings.
 7. Natural dry density in lbs./sq. ft. for all strata.
 8. Unconfined compressive strength in tons/sq. ft. for all strata.
 9. Water content (percent). Liquid Limit (percent) and plastic limit (percent).
 10. Standard penetration in blows/ft.
- 2.03 Soil boring logs shall be accompanied by a plan drawn to scale showing location of borings in relation to the tracks, the elevation of ground surface at each boring, and the elevation of the top of rail of the tracks.
- 2.04 Soil investigation by auger, wash, or rotary drilling method is not acceptable.
- 2.05 Borings shall be taken no more than two (2) feet from the field stake which marks the boring location. The stake should not be disturbed during boring operations. Lost stakes shall be reinstalled.
- 2.06 Unless a boring hole is actively being worked, it shall be securely covered or otherwise protected until permanently filled. When work at each boring hole is completed, the hole shall be properly filled.
- 2.07 Access to the boring locations must be approved by the Railroad

Company(s). When possible, access shall be from public roads. Licenses for Entry, Insurance and Flag Protection must be obtained by the Contractor in accordance with all applicable MBTA Specifications.

2.08 Boring operations shall be confined to each boring location to the extent possible.

The Contractor shall take necessary precautions to prevent damage to structures and facilities. The site shall be restored to a condition satisfactory to the Railroad Company(s).

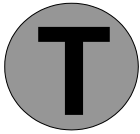

**MASSACHUSETTS BAY
TRANSPORTATION
AUTHORITY**

RAILROAD OPERATIONS DIRECTORATE

XIII

FIBER OPTIC CABLE SPECIFICATIONS

SECTION 1. GENERAL

- 1.01 The purpose of the following standards is to provide basic information about the MBTA's requirements with respect to the design and construction of fiber optic cables on MBTA Railroad Property to fiber optic cable companies and their Contractors.
- 1.02 All work performed on or affecting MBTA Railroad Property must be designed and constructed in accordance with the Commuter Rail Design Standards (Vol. I and II), MBTA Book of Standards, Railroad Operations Specifications and the following standards. Additional job specific requirements will be contained in the MBTA's Fiber Optic License Agreement and can be obtained by contacting:

AGM for Real Estate and Asset Development
Ten Park Plaza
Boston, MA 02116

The Director of Engineering for MBTA Railroad Operations or their designated representative will be responsible for the approval of all work. No modifications, changes or deletions will be made without their approval.

SECTION 2. PROJECT REVIEW AND COORDINATION

- 2.01 All Drawings and specifications shall be reviewed and approved by the MBTA and Railroad Company(s) prior to construction. The MBTA must approve the construction schedule and sufficient Railroad Company(s) personnel must be available before work begins.
- 2.02 If another fiber optic cable company has previous or exclusive rights along the proposed route, the alignment and cable location must be approved in accordance with existing agreements.
- 2.03 The fiber optic cable companies must coordinate the construction with others to minimize the disruptions to the MBTA railroad operations.

SECTION 3. CONDUCT OF WORK

- 3.01 In order to minimize the manpower requirements of the Railroad Company(s) and afford better control, supervision, and protection, the Contractor will conduct their work sequentially and minimize the number of crews and their proximity. Crews should be confined geographically to an area that can be covered easily by a minimum number of Railroad Company(s) personnel. This can be accomplished by a block method of construction. A construction block will be used and is a 1-4 mile segment of right of way in which up to 3 fiber optic cable installation crews can work. The crews can work within the construction block, but cannot work outside of it. The construction block

must move as a unit along the right of way. The crews cannot work two blocks concurrently.

SECTION 4. CONSTRUCTION SCHEDULE

- 4.01 The fiber optic company or its Contractor will submit a schedule of work to the MBTA for approval. The schedule will be based on methods of construction acceptable to the MBTA and Railroad Company(s). No work shall begin prior to approval by the MBTA.
- 4.02 Any changes or modifications to the schedule proposed by the fiber optic company or its Contractor must be submitted to and approved by the MBTA prior to implementation. The MBTA, however, may be required to change or modify the construction schedule on account of its operations, maintenance requirements, or manpower shortages. In this event, the MBTA will give the fiber optic cable company as much advance notice as possible.
- 4.03 Construction schedules will be reviewed and updated every two (2) weeks or as required.

SECTION 5. ESTIMATE OF EXPENSES

- 5.01 An estimate of anticipated expenses will be provided based on durations provided by the fiber optic cable company or their Contractor and construction schedules approved by the Railroad Company(s). Any changes in the schedule will cause the estimate to be revised. The fiber optic cable company or their Contractor will be responsible for all of the costs incurred by the MBTA and Railroad Company(s) in support of the construction activities. This includes design review, engineering support, administration and supervision.

SECTION 6. BILLING

- 6.01 The fiber optic cable company or its Contractor will be required to pay for railroad protective services in advance of costs incurred.